



# Towards Converged Millimeter-Wave/Terahertz Wireless Communication and Radar Sensing

GAO Xiang, Saqlain MUHAMMAD, CAO Xiaoxiao, WANG Shiwei, LIU Kexin, ZHANG Hangkai, and YU Xianbin

(College of Information Science and Electronic Engineering, Zhejiang University, Hangzhou, Zhejiang 310027, China)

DOI: 10.12142/ZTECOM.202001011

<http://kns.cnki.net/kcms/detail/34.1294.TN.20200316.1103.003.html>, published online March 17, 2020

Manuscript received: 2019-12-18

**Abstract:** Converged communication and radar sensing systems have attained increasing attention in recent years. The development of converged radar-data systems is reviewed, with a special focus on millimeter/terahertz systems as a promising trend. Firstly, we present historical development and convergence technology concept for communication-radar systems, and highlight some emerging technologies in this area. We then provide an updated and comprehensive survey of several converged systems operating in different microwave and millimeter frequency bands, by providing some selective typical communication and radar sensing systems. In this part, we also summarize and compare the system performance in terms of maximum range/range resolution for radar mode and Bit Error Rate (BER)/wireless distance for communication mode. In the last section, the convergence of millimeter/terahertz communication-radar system is concluded by analyzing the prospect of millimeter-wave/terahertz technologies in providing ultrafast data rates and high resolution for our smart future.

**Keywords:** system convergence; wireless communication; radar sensing; millimeter-wave; terahertz

**Citation:** (IEEE Format): X. Gao, S. Muhammad, X. X. Cao, et al., "Towards converged millimeter-wave/terahertz wireless communication and radar sensing," *ZTE Communications*, vol. 18, no. 1, pp. 73 - 82, Mar. 2020. doi: 10.12142/ZTECOM.202001011.

## 1 Introduction

The invention of radio ushered the history of mankind into a new era, and wireless communication and radar sensing are two prominent types of radio applications.

Radar detection plays an important role in our daily life. Up to date, it has been used to cover different aspects of requirements with its distinctive properties. For instance, SHERRIF et al. used 94-GHz Frequency Modulated Continuous Wave (FMCW) radar to invent a powered wheelchair in 2017 which can help the handicapped to improve their mobility when facing some inconvenient phenomena, such as entering in a building with non-barrier-free areas [1], and ZHANG et al. realized hand gesture recognition using double channels 5.8 GHz Doppler-radar [2].

In order to recognize targets more accurately, the tendency

pushes the radar frequency into higher bands, such as the millimeter-wave band, even the terahertz band. Besides that, millimeter-wave and terahertz are indeed more resistant to fog, snow, and other natural conditions than presently available laser radar. The first application of the millimeter wave in the radar was traced back in 1958, when C. W. TOLBERT used a millimeter radar to successfully receive 8.6 mm (34.8 GHz) and 4.3 mm (69.7 GHz) signals reflected from a phantom target [3]. After that, many researchers devoted themselves to explore this specific area. For example, an active millimeter-wave radar system operated over the frequency band 15 - 40 GHz was used to obtain information about the structure of dressing materials and hand support cast [4], and a millimeter-wave radar permits short-range, high-resolution detection and imaging of the airport movement area for safety [5].

Moreover, the fast growing industry researches for remote sensing applications, such as Light Detection And Ranging (LIDAR), which can provide high resolution and be used for the mapping and monitoring of wetland to monitor sea levels.

This work is supported in part by National Natural Science Foundation of China (NSFC) under Grant No. 61771424, and in part by Natural Science Foundation of Zhejiang Province under Grant No. LZ18F010001.

By comparison, terahertz sensing technology has some advantages, as terahertz waves provide better capability of penetrating some materials, less atmospheric disturbance as well as less difficulty in tracking the beam.

The territory of wireless communication was traced back to 1880, when Alexander invented and patented a particular telephone that conducted audio conversations wirelessly over modulated light beam. In the modern era of wireless communication, 5G technologies are currently widely researched in the international academia and industry, targeting a downloading speed of up to 10 Gbit/s. However, it has been reported that by 2020, the number of connecting wireless devices will exceed more than 20 million, which must have a stringent demand of more frequency spectrum resources.

Moving forward, new technologies to converge communication-radar systems would be highly appreciated. Definitely, this further development will not only enable the efficient usage of the spectrum, but also bring about many benefits including architecture unification and simplification, functional re-configuration, energy enhancement, as well as cost reduction. The early work on fusing wireless communication and radar sensing was reviewed in 1987, when the NASA space shuttle orbiter was operated either as a radar system for rendezvous with other space vehicles, or as a two-way communication system with the ground through the tracking and data relay satellite system [6]. After that, the converged radar-communication system has made tremendous progress and combined with numerous emerging technologies for enhancing its performance. Up to date, the radar resolution in such joint systems has been retained up to centimeter level [7], and the data rate gets to over 10 Gbit/s in a photonic system [8].

The rest of this paper is organized as follows. An overview of convergence technology for joint system design is reviewed in Section 2. Several selective demonstrations of joint systems and their performances comparison are presented in Section 3. In Section 4, a concept of integrating millimeter-wave/terahertz radar sensing and wireless communication is highlighted. Finally, we give the conclusion in Section 5.

## 2 Overview of Convergence Technology for Converged Systems

Under specific circumstances, it is quite difficult to precisely combine different functions required to operate communication and radar systems simultaneously. To cope with this problem, convergence operations are typically done using reconfigurable circuits based on software programming, and hence provide a good flexibility to implement joint system operation together.

### 2.1 Communication-Radar Convergence Schemes

**Table 1** summarizes some typical single and multi-carrier communication-radar convergence schemes that have been recently proposed in [7], [9] – [18]. Integrating wireless and sens-

ing functions within a single platform helps reduce system cost and complexity as well as increase operational reliability. For single carrier systems, communication and radar signals are divided into the frequency domain [17], code domain [7], [19] and time domain [18], [20], [21], while multiple carrier techniques are also employed to achieve multifunctionality [22]. The code domain (spread spectrum) in single carrier systems is a popular technique that was first implemented for two-way transmission system for vehicular communication and ranging applications [23]. Spread spectrum techniques have been exploited for convergence functions such as direct-sequence spread spectrum (DSSS) [7], [23] – [26] and Chirp Spread Spectrum (CSS) [19]. Code based schemes provide secure communication and high resolution ranging at the price of excessive spectrum resources utilization for data communication. Moreover, different users share the same frequency band simultaneously but using different codes, which is beneficial for multiuser application scenarios. However, the spread spectrum techniques have two main disadvantages for radar ranging and Doppler estimation. One is limited peak to side-lobe ratio caused by imperfect autocorrelation features of codes and the other is a huge computational time required by the spread spectrum technique for Doppler processing. Generally, the spread spectrum technique is more complex, costly and less efficient in view of system implementation.

Similarly, in multicarrier systems, the Orthogonal Frequency-division Multiplexing (OFDM) technique is the most favorable choice and has been widely used for communication and radar systems. The main advantage of OFDM technique is that it resolves the problem of radar ranging and Doppler processing [27], [28] compared with its counterparts. In recent years, several signal processing techniques have been proposed and implemented. In the beginning, matched filters were used to execute range and Doppler estimation in [29] – [34]. OFDM processing algorithms were proposed [35] – [38] to counter low dynamic range and preserve the resolution and processing gain of correlation based processing method. Advanced OFDM algorithms for joint range and Doppler estimation have much higher dynamic range than the spread spectrum approach in view of high Signal-to-noise Ratio (SNR) level. Moreover, the OFDM technique is efficient in estimating the Doppler frequency from the target range. The OFDM technique requires complex signal processing, and high peak-to-average power increases its implementation cost and still hinders its widespread applications.

Time domain duplex has also attracted research interest due to its high spectral efficiency, easy system implementation and low cost [18], [20], [21], [39], [40]. This scheme minimizes mutual interference as radar and communication functions operate independently. Subsequently, various kinds of waveforms and modulation techniques for converged systems can be applied, respectively, according to the application scenarios.

On the other hand, Radio-over-Fiber (RoF) technology has also become the exciting research area for military and high

▼Table 1. Summary of fusion technology

Method Type	System Type	Domain	Radar Mode	Communication Mode	Year	Reference	
Electronics	Joint Waveform	Frequency	Pulse (DSSS)	ASK	2002	[23]	
			Pulse (DSSS)	MSK	2016	[12]	
		Code	Pulse	DQPSK	2007	[17]	
			Pulse (DSSS)	PPM	2010	[7]	
		Multiple Carrier	---	Pulse (CSS)	QPSK	2011	[16]
				Pulse (OFDM)	PSK	2017	[11]
				Pulse	CPM	2017	[13]
				Pulse (OFDM)	OFDM	2009	[60]
				CW (SFCW)	DPSK	2015	[14]
				Trapezoidal FMCW	BPSK	2011	[9]
Time-Domain Duplex	---	Time	FMCW	FSK	2008	[18]	
			Trapezoidal FMCW	PSK	2013	[15]	
Photonics	---	Multiple Carrier	---	Pulse (OFDM)	16-QAM	2017	[8]

ASK: Amplitude Shift Keying

BPSK: Binary Phase Shift Keying

CPM: Continuous Phase Modulation

CSS: Chirp Spread Spectrum

DPSK: Differential Phase Shift Keying

DQPSK: Differential Quadrature Phase-shift Keying

DSSS: Direct-Sequence Spread Spectrum

FMCW: Frequency Modulated Continuous Wave

FSK: Frequency Shift Keying

MSK: Minimum-shift Keying

OFDM: Orthogonal Frequency-Division Multiplexing

PPM: Pulse Position Modulation

PSK: Phase Shift Keying

QAM: Quadrature Amplitude Modulation

QPSK: Quadrature Phase Shift Keying

SFCW: Stepped Frequency Continuous Wave

speed sensing applications [41]. The OFDM technique has also been used in RoF system for efficient utilization of spectrum and less inter-symbol interference. Recently, 30 GHz converged OFDM communication and radar sensing system has been reported in [8].

Generally, radar systems can be classified as Continuous-wave (CW) and pulsed modes. FMCW and Linear Frequency Modulated (LFM) pulses are categorized under CW and pulse radar, respectively. FMCW radars have been widely used in the automobile field, and have their distinctive features of lower emission-peak-power, simple modulation and signal processing, and low cost. The FMCW radars have been demonstrated in synthetic aperture radar systems [42], radar imaging [43] - [45] and range localization [46], [47]. Another important kind of CW radar is Frequency-Stepped Continuous Wave (FSCW), as demonstrated in [48], [49]. FSCW technique is more suitable for Ground Penetrating Radar (GPR) since it has such advantages as wide dynamic range, high mean power, low noise figure and probably the most important one, the possibility of shaping the power spectral density [50]. It is important to note that FMCW and FSCW radar waveforms are mostly used in time domain duplex scheme due to its low cost and easy implementation.

With regard to pulse radar systems, pulse modulation realizes signal oscillation that only occurs at a specified time interval. LFM signals have been widely used in pulse radar systems [51], [52] featuring some advantages, such as non-sensitive to the Doppler frequency shift of echo, simple radar signal

processing, superior range resolution, and radial velocity resolution. Besides that, Non-Linear Frequency Modulation (NLFM) [53], phase encoding [54], and time-frequency encoding [55] are supplement technologies of pulse modulation.

In converged systems, digital modulation techniques have also been employed for better quality and efficient communication and hence achieve good system performance. Digital modulation provides benefits over analog modulation including available bandwidth and has better noise immunity. In this paper, we generally discuss the modulation techniques listed in Table 1. The Pulse Position Modulation (PPM) format, implemented non-coherently, is suitable for optical communication. However, this format has multipath interference and synchronization problem. Differential Quadrature Phase-shift Keying (DQPSK) technique has been used to avoid the problem associated with lack of phase synchronization between transmitter and receiver. Continuous Phase Modulation (CPM) modulates the data bits in a continuous manner and therefore has high spectral efficiency. This is particularly important in wireless communication where bandwidth is expensive. Similarly, other simple modulation formats like Binary Phase Shift Keying (BPSK), On-Off Keying (OOK) and frequency Shift Keying (FSK) have been commonly used in wireless and optical communication. Both BPSK and OOK have the same bandwidth and not suitable for high data rates applications. The FSK technique occupies more spectrum and is used for high frequency radio applications. The MSK format encodes each bit as a half sinusoid and reduces non-linear dis-

tortion. On the other hand, the Quadrature Amplitude Modulation (QAM) format supports high data rate applications and has been widely used in modern wireless and optical fiber communications. Various combinations of amplitude and phase have been employed to achieve high data rates.

Hence, it is important to choose an appropriate combination of modulation formats, which should enable system optimization and performance improvement.

## 2.2 Single Carrier and Multiple Carrier Systems

Converged communication-radar systems can be also classified on the basis of carrier types, such as single carrier and multiple carrier. Certainly, both of these two methods have their respective advantages and drawbacks.

From Table 1, we can see that single-carrier systems have been paid more attention due to their simplicity, more stability and relatively mature technology compared with other systems [12], [16], [17]. However, their drawbacks are obvious as well. Spectrum overlapping between radar and communication signals, particularly with data transmission at high data rates, may lead to inter-symbol interference, and as a consequence the system is not extensively used.

Multiple-carrier based schemes, especially OFDM has been widely used in the wireless communication system, as it shows superiority compared with single-carrier in terms of high spectral efficiency, strong rigidity to inter-symbol and inter-channel interference. However, OFDM technology uses subcarrier modulation, which consequently requires costly and complex transceiver design and implementation. The OFDM technique has also been proposed in the design of radar waveform [56], and has been demonstrated in a Multiple Input and Multiple Output (MIMO) radar system [57], for multiple target detection and estimation [58] and drone detection [59], etc. It is worthwhile to note that an OFDM based radar system does not have the range-Doppler estimation which may have serious influence on the precision of range finding [27], [28].

## 3 Demonstration of Various Joint Systems

In past years, several converged communication and radar systems have been developed. In this section, we selectively present some joint systems that operated in different microwave and mm-wave frequency bands. Single and multi-carrier based converged systems listed in Table 1 are simple and low cost design and provide more consistent performance for both radar and communication modes. Moreover, their practical implementation and system performance of both communication and sensing functions are also discussed and their performance will be compared at the end of this section.

### 3.1 Single Carrier System

As an example, a single transceiver was proposed to work for two modes in [7], serving as a communication device and a location detector simultaneously. Fig. 1 shows the experimental

system based on PPM that was conducted for communication and accurate location finding based on time reversal process. In this setup, the communication and radar mode ranges are 10 m and 3 m respectively. A 60-GHz system with approximately 300 ps pulse width and modulated signal almost of 3 GHz bandwidth obtained an experimental result for a data rates of up to 200 Mbit/s with measured bit error rate (BER) of less than  $10^{-6}$ . This system prototype realizes 10 m wireless communication and a radar range resolution of 12.4 cm within the scope of 3 m. To alleviate the multipath interference, a synchronizer was used in the setup to synchronize the incoming signals received from other sensors.

### 3.2 Multiple Carrier System

As aforementioned, MIMO technology has been widely used in both communication and radar systems [10]. MIMO system typically uses OFDM. This multiplexing technique is used to ensure the separation of each frequency component in order to overcome multi-path interference, which is challenging for the implementation of MIMO systems [57]. For illustration purpose, an OFDM based system is presented here [60].

Fig. 2 shows the joint system based on MIMO technology and this system was setup in the laboratory range of 5 m for both radar and communication modes although the communication mode range could be made more than 10 m. The gen-

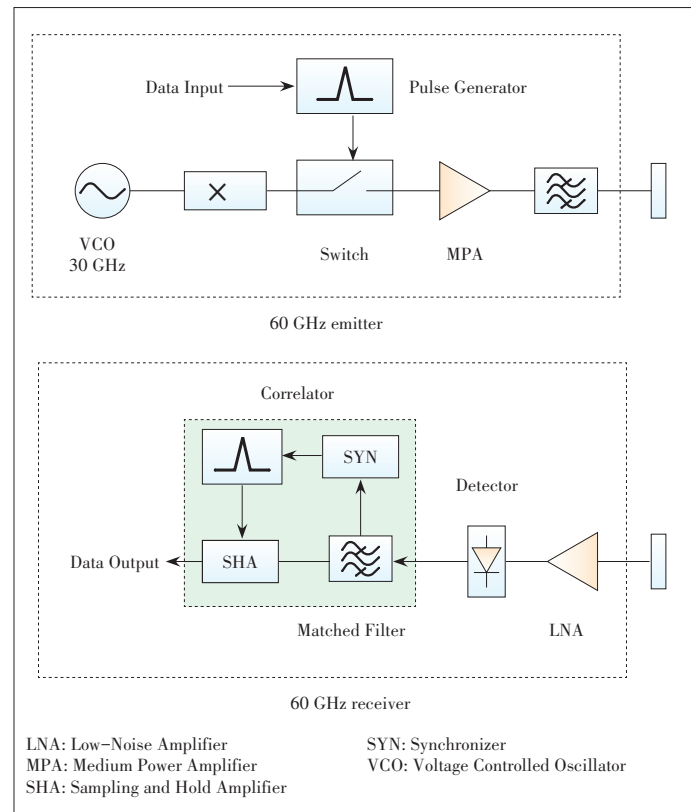

▲ Figure 1. A 60-GHz joint communication and radar system based on Pulse Position Modulation (PPM) technique [7].

erated OFDM signal is up-converted and amplified in the analog front-end section. The transmitted signal bandwidth is 7 – 8 GHz, aiming at airborne radar sensor networks. The experimentally obtained range resolution is about 0.30 m, which agrees very well with theoretical range resolution. It should be noted that the effective bandwidth is only 500 MHz when calculating the theoretical range resolution. In addition, data transmission capability is 57 Mbit/s by using 64 sub-carriers.

### 3.3 Duplex Time-Domain System

**Fig. 3** shows a proposed time domain duplex system based on Trapezoidal Frequency Modulated Continuous Wave (TFM-CW) for radar and Binary Phase Shift Keying (BPSK) for communication [9].

In the radar mode, a Direct Digital Synthesizer (DDS) is used to deal with the transmitted signal, which is then filtered and up converted to an Intermediate Frequency (IF) signal. Further, the IF signal is split into two portions: one is converted to a Radio Frequency (RF) signal and then radiated via the transmitting antenna; the other is preserved for demodulation. On the receiver side, the reflected RF wave captured by the receiver antenna is converted back into the IF domain after amplification, which as a result is mixed with the preserved one for evaluating the range and velocity of the target.

In the communication mode, the modulated signal is transmitted in the same way as in the radar mode. The BPSK modulation format is selected for enhancing the noise and distortion tolerance.

This system operates within the frequency range from 24.075 GHz to 24.175 GHz. The demonstrated data rate is 50 Mbit/s with measured BER of less than  $10^{-6}$ , and meanwhile, the maximum detectable radar range is 100 m with a range resolution of 1.5 m, which indicates the maximum measurable velocity is approximately 260 km/h.

**Fig. 4a** represents the physical photograph of the radar mode of duplex time domain system and shows six targets and their arrangements in front of the system. **Fig. 4b** shows

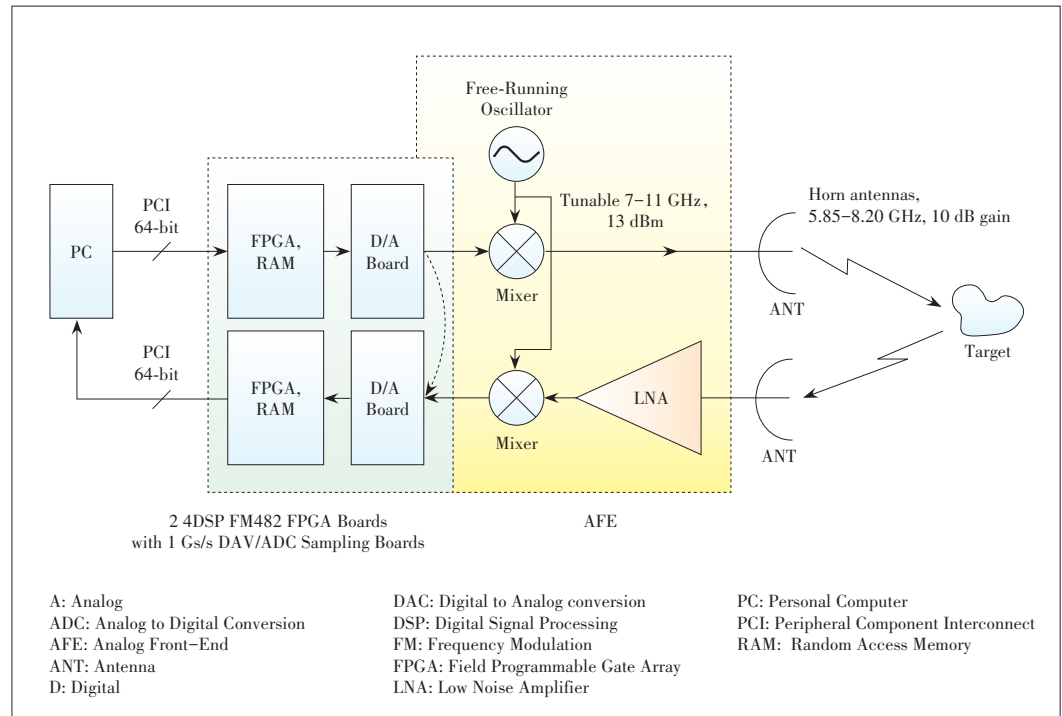

▲ **Figure 2.** A joint radar and communication system based on Orthogonal Frequency-Division Multiplexing (OFDM) Multiple Input and Multiple Output (MIMO) technique [60].

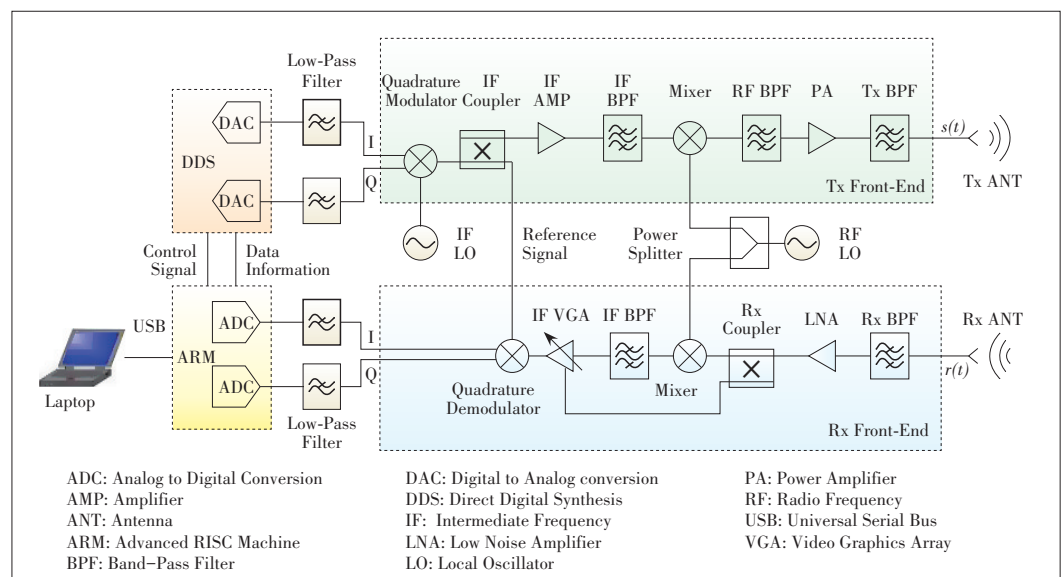

▲ **Figure 3.** A joint communication and radar system based on Binary Phase Shift Keying (BPSK) technique [9].

the frequency estimation by using a Fast Fourier Transform (FFT) with zero padding.

### 3.4 RoF System

In the past decades, microwave photonics has gained a lot of attention due to its attractive capacity of delivering “last mile” wireless signals. This technology potentially supports large bandwidth, and is capable of generating high frequency signals with better performance in a noisy environment [61], [62]. Therefore, RoF technology has been extensively used for both radar systems and communication systems [63] – [67]. For instance, a system based on RoF technology was proposed to perform both communication and radar sensing functionalities, as shown in Fig. 5 [8]. In the radar mode, it uses OFDM technique with 10.1 GHz bandwidth. With respect to the wireless communication mode, an Arbitrary Waveform Generator (AWG) is first used to generate a 7 GHz IF signal with 3.62 Gbaud 16-QAM on a single carrier. The

IF carrier of 7 GHz is then up-converted to 31 GHz, filtered to eliminate the side-band spurious noise, and modulated onto 1.55 μm light via an Mach-Zehnder Modulator (MZM) and transmitted over the fiber. The modulated light signal after fiber transmission is detected by a Photodiode (PD) and then eventually emitted to free space. The system realizes up to 14.5 Gbit/s data rate within distance of 10 m and the minimum ranging resolution of 5 cm.

### 3.5 Performance Comparison

Here we summarize and compare performance of the demonstrated communication and radar systems, as presented in Table 2.

As we can see, the dual mode 60-GHz system for automotive applications in [7] supports a better data rate compared to other electronic joint systems. In the communication mode, this system has a confined range of 10 m due to serious absorption of oxygen for V-band and U-band frequency signals. Similarly, for the radar mode, it has a superior range resolution of 12.4 cm by exploring 3 GHz bandwidth. The 24-GHz integrated radio and radar system in [9] has dissimilar performance compared with [7]. A joint system with the operating frequency range of 7 – 8 GHz shows an average performance and a worse BER of  $5 \times 10^{-2}$  compared with all the other systems. From above discussion, we conclude that the technologies for converged systems still need more maturity for better performance. The emerging technologies including mm-wave and terahertz facilitate a better feasibility of de-

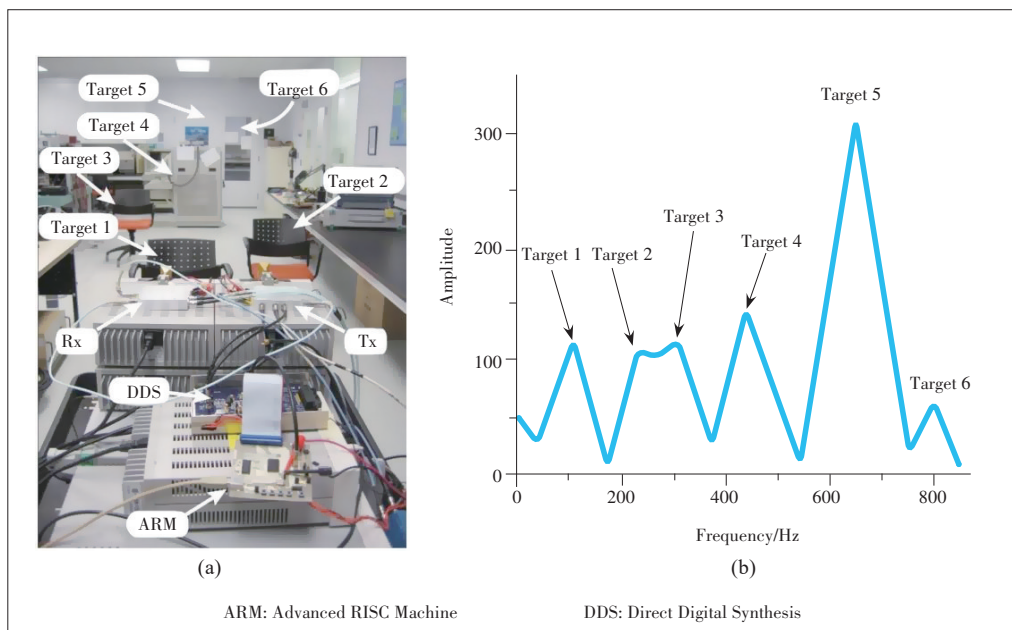

▲ Figure 4. (a) Picture of the measurement setup of radar mode; (b) frequency estimation [9].

▼ Table 2. Performance comparison of the demonstrated joint systems

References	Carrier Frequency/GHz	Modulation Format	Communication Mode			Signal Type	Radar Mode		
			Range/m	Data Rate/(Mbit/s)	BER		Bandwidth/MHz	Range/m	Range Resolution/cm
[7]	60	PPM	10	200	$<1 \times 10^{-6}$	Pulse (single)	3 000	3	12.4
[9]	24.125	BPSK	200	50	$<1 \times 10^{-6}$	TFMCW	100	70	165
[60]	7.0 – 8.0	OFDM	5	57	$<5 \times 10^{-2}$	Pulse (OFDM)	1 000	5	30
[8]	25 – 35	16-QAM	10	14 500	$<1 \times 10^{-3}$	Pulse (OFDM, Photonics)	10 000	5	5

BER: Bit Error Rate  
BPSK: Binary Phase Shift Keying

PPM: Pulse Position Modulation  
OFDM: Orthogonal Frequency Division Multiplexing

QAM: Quadrature Amplitude Modulation  
TFMCW: Trapezoidal frequency modulated continuous-wave

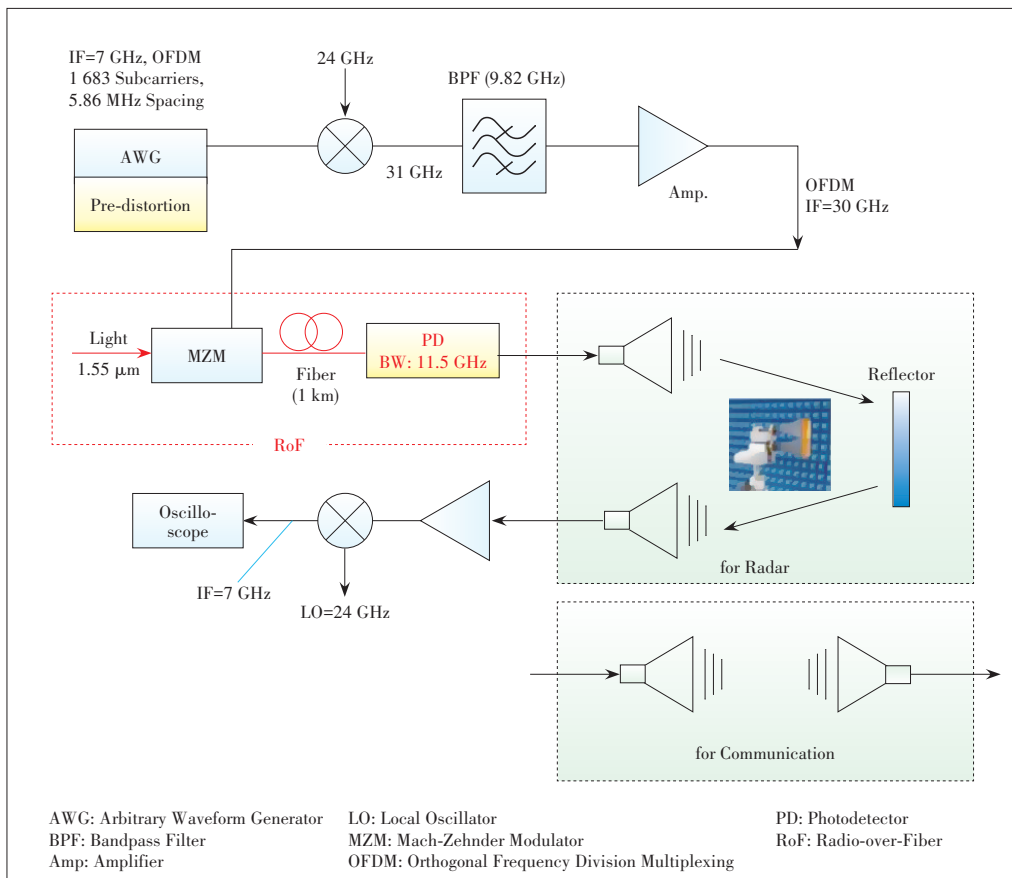

▲ Figure 5. A joint radar and communication system based on RoF technology [8].

signing a well-structured converged system.

## 4 Towards a Millimeter-Wave/Terahertz Converged Radar and Communication System

Based on the technical survey above, we can see converged millimeter-wave systems have exhibited better capacity for both radar and communication modes, supporting better ranging resolution and higher data rates. This is fully understandable since there are larger frequency bandwidth available in the higher frequency bands. In fact, this is believed to be the technical tendency from both industrial and academic sides, exploring high frequency bands (millimeter-wave, even terahertz (100 GHz - 10 THz)).

For sake of high resolution radars systems in the future, millimeter wave/terahertz for radar sensing can provide superior performance compared to microwave. Millimeter wave/terahertz sensors have such distinctive features as larger bandwidth enabling better ranging resolution, low possibility of interception and interference, and smaller antenna size than low frequency microwave. Millimeter wave radar systems have been recently well-developed for automotive applications at 24 GHz and 77 GHz [68], [69], and most recently, a terahertz

photonic radar has been reported as its potential of enabling mm-scale range resolution [70].

On the other hand, to accommodate the ever increasing wireless data stream, the overall data rate is expected to reach beyond 100 Gbit/s, and eventually Tbit/s; in this context, the carrier frequency naturally goes into the millimeter-wave and terahertz frequency regions [71]. Recently, a lot of efforts are devoted to broadband terahertz wireless communications, and several demonstrations of beyond 100 Gbit/s in the terahertz band have been reported, attributed to the extremely broad terahertz bandwidth available [72] - [75].

Up to date, millimeter-wave and terahertz have been explored for either radar or communication purposes, however, the converged system in such high frequency is not demonstrated yet. This

thriving area needs more breakthrough from academia and industry to develop converged systems based on emerging technologies in near future. Therefore, more technological progress in mm-wave/terahertz is essential for our smart future.

The previous work on the converged systems in the microwave band has opened a door for the researchers to develop new converged systems based on modern technologies. Moreover, the features of millimeter and terahertz wave technologies can provide a solution to a cost-effective, simple and light, and high bandwidth converged system to support higher data rates compared with microwave technology-based system.

## 5 Conclusions

The convergence of communication and radar sensing functions within a single platform is expected to provide a better solution to a low cost and high efficiency multi-functional system. In this paper, we have overviewed the technological trend of converged communication-radar systems. We have also presented the convergence technology and summarized several typical converged systems operating in the microwave and millimeter-wave bands. Future convergence work for making the terahertz wireless communication systems robust in differ-

ent indoor environments will be highly appreciated, e. g. , the precise imaging capabilities of radar sensing in the terahertz range can assist terahertz communications system to optimize the indoor scattering environment by providing reflection parameters of different objects, as well as to help radio channel modeling in a particular indoor scenario.

For sake of better ranging resolution and higher data rates, the technical tendency in the near future is expected to explore mm-wave/terahertz high frequency bands for such converged systems, from both industrial and academic sides, while a lot of research is still needed to push convergence forward.

## References

- [1] ABDULATIF S, KLEINER B, AZIZ F, et al. Stairs Detection for Enhancing Wheelchair Capabilities Based on Radar Sensors [C]//IEEE 6th Global Conference on Consumer Electronics (GCCE). Nagoya, Japan, 2017: 1 - 4. DOI: 10.1109/gcce.2017.8229270
- [2] ZHANG J J, TAO J K, SHI Z G. Doppler-Radar Based Hand Gesture Recognition System Using Convolutional Neural Networks [M]//Lecture Notes in Electrical Engineering. Singapore, Singapore: Springer, 2018: 1096 - 1113. DOI: 10.1007/978-981-10-6571-2\_132
- [3] TOLBERT C, STRAITON A, BRITT C. Phantom Radar Targets at Millimeter Radio Wavelengths [J]. IRE Transactions on Antennas and Propagation, 1958, 6 (4): 380 - 384. DOI:10.1109/tap.1958.1144609
- [4] OWDA A Y, SALMON N, ANDREWS D, et al. Active Millimeter-Wave Radar for Sensing and Imaging through Dressing Materials [C]//IEEE SENSORS. Glasgow, UK, 2017. DOI: 10.1109/icsens.2017.8234228
- [5] GALATI G, PIRACCI E G, FERRI M. ResolutionHigh, Millimeter-Wave Radar Applications to Airport Safety [C]//8th International Conference on Ultrawideband and Ultrashort Impulse Signals (UWBUSIS). Odessa, Ukraine, 2016: 21 - 26. DOI: 10.1109/uwbuis.2016.7724144
- [6] CAGER R, LAFLAME D, PARODE L. Orbiter Ku-Band Integrated Radar and Communications Subsystem [J]. IEEE Transactions on Communications, 1978, 26(11): 1604 - 1619. DOI: 10.1109/tcom.1978.1094004
- [7] BOCQUET M, LOYEZ C, LETHIEN C, et al. A Multifunctional 60-GHz System for Automotive Applications with Communication and Positioning Abilities Based on Time Reversal [C]//7th European Radar Conference. Paris, France, 2010: 61 - 64
- [8] UMEZAWA T, JITSUNO K, KANNO A, et al. 30-GHz OFDM Radar and Wireless Communication Experiment Using Radio over Fiber Technology [C]//Progress in Electromagnetics Research Symposium—Spring (PIERS). St Petersburg, Russia, 2017: 22 - 25. DOI: 10.1109/piers.2017.8262288
- [9] HAN L, WU K. 24-GHz Integrated Radio and Radar System Capable of Time-Agile Wireless Communication and Sensing [J]. IEEE Transactions on Microwave Theory and Techniques, 2012, 60(3): 619 - 631. DOI: 10.1109/tmtt.2011.2179552
- [10] HU L, DU Z C, XUE G R. Radar-Communication Integration Based on OFDM Signal [C]//IEEE International Conference on Signal Processing, Communications and Computing (ICSPCC). Guilin, China, 2014: 442 - 445. DOI: 10.1109/icspcc.2014.6986232
- [11] WANG W Q, ZHENG Z, ZHANG S. OFDM Chirp Waveform Diversity for Co-Designed Radar-Communication System [C]//18th International Radar Symposium (IRS). Prague, Czech Republic, 2017. DOI: 10.23919/IRS.2017.8008139
- [12] HUANG R Q, ZHAO X L, ZHANG Q, et al. Spectrum Extension Research of Radar-Communication Integrated Waveform [C]//2nd IEEE International Conference on Computer and Communications (ICCC). Chengdu, China, 2016: 1804-1808. DOI: 10.1109/compcomm.2016.7925013
- [13] ZHANG Y, LI Q Y, HUANG L, et al. Waveform Design for Joint Radar-Communication System with Multi-User Based on MIMO Radar [C]//IEEE Radar Conference (RadarConf). Seattle, USA, 2017: 415 - 418. DOI: 10.1109/radar.2017.7944238
- [14] HU F, CUI G L, YE W, et al. Integrated Radar and Communication System Based on Stepped Frequency Continuous Waveform [C]//IEEE Radar Conference (RadarConf). Arlington, USA, 2015: 1804 - 1807. DOI: 10.1109/radar.2015.7131155
- [15] MOGHADDASI J, WU K. Improved Joint Radar-Radio (RadCom) Transceiver for Future Intelligent Transportation Platforms and Highly Mobile High-Speed Communication Systems [C]//IEEE International Wireless Symposium (IWS). Beijing, China, 2013. DOI: 10.1109/ieeee-iws.2013.6616796
- [16] XIE Y N, TAO R, WANG T. Method of Waveform Design for Radar and Communication Integrated System Based on CSS [C]//First International Conference on Instrumentation, Measurement, Computer, Communication and Control. Beijing, China, 2011: 737 - 739. DOI: 10.1109/imccc.2011.187
- [17] WINKLER V, DETLEFSEN J. Automotive 24 GHz Pulse Radar Extended by a DQPSK Communication Channel [C]//European Radar Conference. Munich, Germany, 2007: 138 - 141. DOI: 10.1109/eurad.2007.4404956
- [18] STELZER A, JAHN M, SCHEIBLHOFER S. Precise Distance Measurement with Cooperative FMCW Radar Units [C]//IEEE Radio and Wireless Symposium. Orlando, USA, 2008: 771 - 774. DOI: 10.1109/rws.2008.4463606
- [19] SADDIK G N, SINGH R S, BROWN E R. Ultra-Wideband Multifunctional Communications/Radar System [J]. IEEE Transactions on Microwave Theory and Techniques, 2007, 55(7): 1431 - 1437. DOI: 10.1109/tmtt.2007.900343
- [20] KONNO K, KOSHIKAWA S. Millimeter-Wave Dual Mode Radar for Headway Control in IVHS [C]//IEEE MTT-S International Microwave Symposium Digest. Denver, USA, 1997: 1261 - 1264. DOI:10.1109/mwysym.1997.596556
- [21] Han L, Wu K. Radar and Radio Data Fusion Platform for Future Intelligent Transportation System [C]//7th European Radar Conference. Paris, France, 2010: 65 - 68. DOI:10.1109/ACCESS.2016.2530979
- [22] GARMATYUK D, SCHUERGER J, KAUFFMAN K. Multifunctional Software-Defined Radar Sensor and Data Communication System [J]. IEEE Sensors Journal, 2011, 11(1): 99 - 106. DOI:10.1109/jsen.2010.2052100
- [23] MIZUI K, UCHIDA M, NAKAGAWA M, et al. Vehicle-to-Vehicle Communication and Ranging System Using Spread Spectrum Technique [C]//Vehicular Technology Conference. Secaucus, USA, 1993: 2 - 5. DOI: 10.1109/VETEC.1993.507206
- [24] LINDENMEIER S, BOEHM K, LUY J F. A Wireless Data Link for Mobile Applications [J]. IEEE Microwave and Wireless Components Letters, 2003, 13(8): 326 - 328. DOI: 10.1109/lmwc.2003.815706
- [25] XU S, CHEN Y, ZHANG P. Integrated Radar and Communication Based on DS-UWB [C]//3rd International Conference on Ultrawideband and Ultrashort Impulse Signals. Sevastopol, Ukraine, 2006: 142 - 144. DOI: 10.1109/uwbuis.2006.307182
- [26] LIN Z Y, WEI P. Pulse Amplitude Modulation Direct Sequence Ultra Wideband Sharing Signal for Communication and Radar Systems [C]//7th International Symposium on Antennas, Propagation & EM Theory. Guilin, China, 2006. DOI: 10.1109/isape.2006.353326
- [27] FRANKEN G E A, NIKOOKAR H, GENDEREN P. Doppler Tolerance of OFDM - Coded Radar Signals [C]//European Radar Conference. Manchester, UK, 2006: 108 - 111. DOI: 10.1109/eurad.2006.280285
- [28] STURM C, ZWICK T, WIESBECK W. An OFDM System Concept for Joint Radar and Communications Operations [C]//VTC Spring 2009—IEEE 69th Vehicular Technology Conference. Barcelona, Spain, 2009. DOI: 10.1109/vetecs.2009.5073387
- [29] TIGREK R F, DE HEIJ W J A, GENDEREN P V. Multi-Carrier Radar Waveform Schemes for Range and Doppler Processing [C]//IEEE Radar Conference. Pasadena, USA, 2009: 2 - 6. DOI: 10.1109/radar.2009.4976986
- [30] LELLOUCH G, TRAN P, PRIBIC R, et al. OFDM Waveforms for Frequency Agility and Opportunities for Doppler Processing in Radar [C]//IEEE Radar Conference. Rome, Italy, 2008. DOI: 10.1109/radar.2008.4720798
- [31] TIGREK R F, DE HEIJ W J A, GENDEREN P V. Solving Doppler Ambiguity by Doppler Sensitive Pulse Compression Using Multi-Carrier Waveform [C]//5th European Radar Conference. Amsterdam, Netherlands, 2008: 72 - 75
- [32] GENDEREN V. Recent Advances in Waveforms for Radar, Including Those



- with Communication Capability [C]//European Radar Conference. Rome, Italy, 2009: 318 – 325
- [33] GENDEREN V. A Communication Waveform for Radar [C]//8th International Conference on Communications. Bucharest, Romania, 2010: 289 – 292. DOI: 10.1109/iccomm.2010.5509110
- [34] BERGER C R, DEMISSIE B, HECKENBACH J, et al. Signal Processing for Passive Radar Using OFDM Waveforms [J]. *IEEE Journal of Selected Topics in Signal Processing*, 2010, 4(1): 226 – 238. DOI: 10.1109/jstsp.2009.2038977
- [35] STURM C, PANCERA E, ZWICK T, et al. A Novel Approach to OFDM Radar Processing [C]//IEEE Radar Conference. Pasadena, USA, 2009: 9 – 12. DOI: 10.1109/radar.2009.4977002
- [36] STURM C, BRAUN M, ZWICK T, et al. A Multiple Target Doppler Estimation Algorithm for OFDM Based Intelligent Radar Systems [C]//7th European Radar Conference. Paris, France, 2010: 73 – 76
- [37] BRAUN M, STURM C, JONDRAL F K. Maximum Likelihood Speed and Distance Estimation for OFDM Radar [C]//IEEE Radar Conference. Arlington, USA, 2010: 256 – 261. DOI: 10.1109/radar.2010.5494616
- [38] BRAUN M, STURM C, JONDRAL F K. On the Single-Target Accuracy of OFDM Radar Algorithms [C]//IEEE 22nd International Symposium on Personal, Indoor and Mobile Radio Communications. Toronto, Canada, 2011: 794 – 798. DOI: 10.1109/pimrc.2011.6140075
- [39] YATTOUN I, LABIA T, PEDEN A, et al. A Millimetre Communication System for IVC2007 [C]//7th International Conference on ITS Telecommunications. Sophia Antipolis, France, 2007: 281 – 286. DOI: 10.1109/ITST.2007.4295879
- [40] ZHANG H, LI L, WU K. 24GHz Software-Defined Radar System for Automotive Applications [C]//European Conference on Wireless Technologies. Munich, Germany, 2007: 138 – 141. DOI: 10.1109/ecwt.2007.4403965
- [41] YU J G, GONG M J, ZHANG M. RoF Communication Technology and Its Application Prospect [J]. *ZTE Communications*, 2009, 7(3): 12 – 15
- [42] JUNG D H, PARK S O. Ku-Band Car-Borne FMCW Stripmap Synthetic Aperture Radar [C]//International Symposium on Antennas and Propagation (ISAP). Phuket, Thailand, 2017. DOI: 10.1109/isap.2017.8228895
- [43] ALIZADEH P, PARINI C, RAJAB K Z. A Low-Cost FMCW Radar Front End for Imaging at 24 GHz to 33 GHz [C]//Loughborough Antennas & Propagation Conference (LAPC). Loughborough, United Kingdom, 2015: 24 – 27. DOI: 10.1109/lapc.2015.7366007
- [44] CHENG P, WANG Z, XIN Q, et al. Imaging of FMCW MIMO Radar with Interleaved OFDM Waveform [C]//12th International Conference on Signal Processing. Hangzhou, China, 2014: 1944 – 1948. DOI: 10.1109/ICOSP.2014.7015332
- [45] GANIS A, NAVARRO E M, SCHOENLINNER B, et al. A Portable 3-D Imaging FMCW MIMO Radar Demonstrator with a 24× 24 Antenna Array for Medium-Range Applications [J]. *IEEE Transactions on Geoscience and Remote Sensing*, 2018, 56(1): 298 – 312. DOI: 10.1109/tgrs.2017.2746739
- [46] SCHEIBLHOFER W, FEGER R, HADERER A, et al. Simultaneous Localization and Data-interrogation Using a 24-GHz Modulated-Reflector FMCW Radar System [C]//IEEE MTT-S International Microwave Symposium (IMS). Honolulu, USA, 2017: 67 – 70. DOI: 10.1109/mwsym.2017.8058669
- [47] PENG Z Y, RAN L X, LI C Z. A K-Band Portable FMCW Radar with Beam-forming Array for Short-Range Localization and Vital-Doppler Targets Discrimination [J]. *IEEE Transactions on Microwave Theory and Techniques*, 2017, 65(9): 3443 – 3452. DOI: 10.1109/tmtt.2017.2662680
- [48] MASKELL D L, WOODS G S. A Frequency Modulated Envelope Delay FSCW Radar for Multiple-Target Applications [J]. *IEEE Transactions on Instrumentation and Measurement*, 2000, 49(4): 710 – 715. DOI: 10.1109/19.863911
- [49] MASKELL D L, WOODS G S. A Multiple-Target Ranging System Using an FM Modulated FSCW Radar [C]//Microwave Conference. Munich, Germany, 1999: 888 – 891. DOI: 10.1109/APMC.1999.833736
- [50] NICOLAESCU I, GENDEREN PVAN, DONGEN K WVAN, et al. Stepped Frequency Continuous Wave Radar Data Preprocessing [C]//Advanced Ground Penetrating Radar. Nantes, France, 2003: 14 – 16. DOI: 10.1109/AG-PR.2003.1207315
- [51] ZHU D K, LIU Y X, HUO K, et al. A Novel High-Precision Phase-Derived-Range Method for Direct Sampling LFM Radar [J]. *IEEE Transactions on Geoscience and Remote Sensing*, 2016, 54(2): 1131 – 1141. DOI: 10.1109/tgrs.2015.2474144
- [52] SHI P F, GUO J M, LV P, et al. The Chirp-based Analog to Information Conversion in the LFM Pulse Compression Radar [C]//CIE International Conference on Radar (RADAR). Guangzhou, China, 2016. DOI: 10.1109/radar.2016.8059317
- [53] KURDZO J M, CHEONG B L, PALMER R D, et al. Optimized NLFM Pulse Compression Waveforms for High-Sensitivity Radar Observations [C]//International Radar Conference. Lille, France, 2014. DOI: 10.1109/radar.2014.7060249
- [54] XIONG Y, CHENG M, GAO Y, et al. Simulation Research on the Use of Phase Encoding Algorithm in Correcting Range Ambiguity for Doppler Weather Radar [C]//International Conference on Information Science and Technology. Nanjing, China, 2011: 761 – 765. DOI: 10.1109/icist.2011.5765356
- [55] NUNN J, WRIGHT L J, SÖLLER C, et al. Large-Alphabet Time-Frequency Entangled Quantum Key Distribution by Means of Time-to-Frequency Conversion [J]. *Optics Express*, 2013, 21(13): 15959. DOI: 10.1364/oe.21.015959
- [56] PETTERSSON M. Multifrequency Complementary Phase-Coded Radar Signal [J]. *Radar, Sonar and Navigation*, 2000, 147(6): 1 – 22. DOI: 10.1049/ip-rsn:20000734
- [57] DONNET B, LONGSTAFF I. Combining MIMO Radar with OFDM Communications [C]//European Radar Conference. Manchester, UK, 2006. DOI: 10.1109/eurad.2006.280267
- [58] SINGH U K, BHATIA V, MISHRA A K. Multiple Target Detection and Estimation of Range and Doppler for OFDM-RADAR System [C]//4th International Conference on Signal Processing and Integrated Networks (SPIN). Noida, India, 2017: 27 – 32. DOI: 10.1109/spin.2017.8049910
- [59] NUSS B, SIT L, FENNEL M, et al. MIMO OFDM Radar System for Drone Detection [C]//18th International Radar Symposium. Prague, Czech, 2017: 1 – 9.
- [60] GARMATYUK D, KAUFFMAN K. Radar and Data Communication Fusion with UWB-OFDM Software-Defined System [C]//IEEE International Conference on Ultra-Wideband. Vancouver, Canada, 2009: 454 – 458. DOI: 10.1109/icuwb.2009.5288748
- [61] WANG F, SHI S, SCHNEIDER G J, et al. Photonic Microwave Generation with High-Power Photodiodes [C]//IEEE Photonics Conference. Bellevue, UAS, 2013: 350 – 351. DOI: 10.1109/IPC.2013.6656581
- [62] LIN B, PAN B W, ZHENG Z, et al. A Review of Photonic Microwave Generation [C]//IEEE Optoelectronics Global Conference (OGC). Shenzhen, China, 2016. DOI: 10.1109/ogc.2016.7590480
- [63] ZHANG F Z, PAN S L. Microwave Photonic Signal Generation for Radar Application [J]. *Electromagnetics: Applications and Student Innovation Competition (iWEM)*, 2016, 2: 2 – 4
- [64] GHELFI P, LAGHEZZA F, SCOTTI F, et al. A Fully Photonics-Based Coherent Radar System [J]. *Nature*, 2014, 507(7492): 341 – 345. DOI: 10.1038/nature13078
- [65] LI R M, LI W Z, WEN Z L, et al. Synthetic Aperture Radar Based on Photonic-Assisted Signal Generation and Processing [C]//Opto-Electronics and Communications Conference (OECC) and Photonics Global Conference (PGC). Singapore, Singapore, 2017. DOI: 10.1109/oecc.2017.8114844
- [66] GHELFI P, LAGHEZZA F, SCOTTI F, et al. Photonic Generation of High Fidelity RF Sources for Mobile Communications [J]. *Journal of Lightwave Technology*, 2017, 35(18): 3901 – 3908. DOI: 10.1109/JLT.2017.2707411
- [67] INOUEI T, IKEDA K, KAKUBARI Y, et al. Millimeter-Wave Wireless Signal Generation and Detection Using Photonic Technique for Mobile Communication Systems [C]//IEEE International Topical Meeting on Microwave Photonics (MWP). Long Beach, USA, 2016: 55 – 58
- [68] MAYER W, GRONAU A, MENZEL W, et al. A Compact 24 GHz Sensor for Beam-Forming and Imaging [C]//9th International Conference on Control, Automation, Robotics and Vision. Singapore, Singapore, 2006: 1 – 6. DOI: 10.1109/icarcv.2006.345160
- [69] ANDRES M, FEIL P, MENZEL W. 3D-Scattering Center Detection of Automotive Targets Using 77 GHz UWB Radar Sensors [C]//6th European Conference on Antennas and Propagation (EUCAP). Prague, Czech, 2012: 3690 – 3693. DOI: 10.1109/eucap.2012.6206580
- [70] ZHANG H K, WANG S W, JIA S, et al. Experimental Generation of Linearly Chirped 350 GHz Band Pulses with a Bandwidth beyond 60 GHz [J]. *Optics Letters*, 2017, 42(24): 5242. DOI: 10.1364/ol.42.005242
- [71] YU X, CHEN Y, GALILI M, et al. The Prospects of Ultra-Broadband THz Wireless Communications [C]//16th International Conference on Transparent Optical Networks (ICTON 2014). Graz, Austria, 2014. DOI: 10.1109/ICTON.2014.6876675

- [72] YU X, JIA S, HU H, et al. 160 Gbit/s Photonics Wireless Transmission in the 300-500 GHz Band [J]. *APL Photonics*, 2016, 1(8): 081301. DOI: 10.1063/1.4960136
- [73] YU X B, ASIF R, PIELS M, et al. 400-GHz Wireless Transmission of 60-Gb/s Nyquist-QPSK Signals Using UTC-PD and Heterodyne Mixer [J]. *IEEE Transactions on Terahertz Science and Technology*, 2016, 6(6): 765 - 770. DOI: 10.1109/tthz.2016.2599077
- [74] JIA S, PANG X, OZOLINS O, et al. 0.4THz Photonic - Wireless Link with 106Gbit/s Single Channel Bitrate [J]. *Journal of Lightwave Technology*, 2018, 36(2): 610 - 616, 2018
- [75] JIA S, YU X B, HU H, et al. 120 Gb/s Multi-Channel THz Wireless Transmission and THz Receiver Performance Analysis [J]. *IEEE Photonics Technology Letters*, 2017, 29(3): 310 - 313. DOI: 10.1109/lpt.2016.2647280

### Biographies

**GAO Xiang** received the B.S. degree from Zhejiang Sci-Tec University, China in 2017. He is currently working towards the M.S. degree at the School of Electronic science and technology, Zhejiang University. His current research interest is terahertz imaging.

**Saqlain MUHAMMAD** received the M.S. degree in electronics communication engineering from the University of Nottingham, Malaysia Campus in 2013. He has been a Ph.D. student at the College of Information Science and Electronic Engineering, Zhejiang University since 2017. His research interests are terahertz communication and channel impairments.

**CAO Xiaoxiao** received the B.S. degree from Anhui University, China in

2017. She is currently working towards the M.S. degree at the School of Electronic science and technology, Zhejiang University. Her current research interest is terahertz imaging.

**WANG Shiwei** received the B.S. degree in electronics science and technology from Harbin Institute of Technology, China in 2016. He is currently working towards the Ph.D. degree in electronics science and technology at Zhejiang University. His current research interests are in the areas of terahertz/microwave photonics and terahertz communications.

**LIU Kexin** received the B.S. degree from Sun Yat-sen University, China in 2016. She received the M.S. degree from the College of Information Science and Electronic Engineering, Zhejiang University in 2019. Her research interest is terahertz communications.

**ZHANG Hangkai** received the B.S. and M.S. degrees from the College of Information Science and Electronic Engineering from Zhejiang University, China in 2018. His research interest is terahertz/microwave photonics.

**YU Xianbin** (xyu@zju.edu.cn) received his Ph.D. degree in 2005 from Zhejiang University, China. From 2005 to 2007, he was a postdoctoral researcher at Tsinghua University, China. Since November 2007, he has been with the Technical University of Denmark, Kongens Lyngby, Denmark, as a Postdoctoral and Assistant Professor, and was promoted to a Senior Researcher in 2013. He is currently a Research Professor with Zhejiang University, China. He has authored or coauthored two book chapters and more than 150 peer-reviewed international journal and conference papers in the area of microwave photonics and optical communications. His current research interests are in the areas of terahertz/microwave photonics, optical fiber communications, ultrafast photonic wireless signal processing, and ultrahigh frequency wireless access technologies.