



To Learn or Not to Learn: Deep Learning Assisted Wireless Modem Design

XUE Songyan¹, LI Ang¹, WANG Jinfei¹, YI Na¹, MA Yi¹, Rahim TAFAZOLLI¹, and Terence DODGSON²

(1. Institute for Communication Systems, University of Surrey, Guildford, GU2 7XH, the United Kingdom;
2. Airbus Defense and Space, Portsmouth, PO3 5PU, the United Kingdom)

Abstract: Deep learning is driving a radical paradigm shift in wireless communications, all the way from the application layer down to the physical layer. Despite this, there is an ongoing debate as to what additional values artificial intelligence (or machine learning) could bring to us, particularly on the physical layer design; and what penalties there may have? These questions motivate a fundamental rethinking of the wireless modem design in the artificial intelligence era. Through several physical-layer case studies, we argue for a significant role that machine learning could play, for instance in parallel error-control coding and decoding, channel equalization, interference cancellation, as well as multiuser and multiantenna detection. In addition, we discuss the fundamental bottlenecks of machine learning as well as their potential solutions in this paper.

Keywords: deep learning; neural networks; machine learning; modulation and coding

DOI: 10.12142/ZTECOM.201904002

<http://kns.cnki.net/kcms/detail/34.1294.TN.20191206.1105.002.html>, published online December 9, 2019

Manuscript received: 2019-09-19

1 Introduction

With the launch of commercial 5G mobile networks in 2019, the research of wireless communications is now well on the way towards Vision 2030 and beyond. Today, the picture of future wireless communications is becoming much clearer than ever. According to ITU Network 2030 Working Group [1], future networks should be architected to support holographic communications and smart connectivity, providing seemingly zero latency, guaranteed ultra-reliability (e. g. 99.9999%), massive Internet of Things (IoT) connectivity, and Tbit/s wireless speed. Communication networks are no longer only a medium for information flow, but also act as distributed computers to form over-the-top (OTT)-like platforms to provide services (such as computing-as-

a-service and design-as-a-service) for vertical users. To achieve this goal, wireless technologies should be fundamentally re-designed to be able to fully explore the spectrum; as such, this is driving the development of extreme physical-layer (PHY) technologies, which are able to handle wireless systems with many nonlinearities, due to the use of very-high order modulations, unexploited mmWave or THz bands, and/or low-cost electronic components (such as low-noise amplifiers (LNAs), mixers, oscillators and low-resolution analog-to-digital converters (ADCs)). Moreover, PHY solutions should be made scalable to the number of connected devices; and they should be parallel computing ready, as future high-performance computing technologies (including future quantum computing technology) rely highly on the parallel computing power.

With such a big picture in mind, machine learning or more specifically, deep learning can play a significant role in the PHY design, at least from the following five aspects:

1) Conventional PHY algorithms, particularly for wireless receivers, are mostly not parallel computing ready. For instance,

This work was supported in part by EU H2020 5G-DRIVE Programme under Grant No. 814956, in part by Airbus Defense and Space, and in part by the UK 5G Innovation Centre (5GIC).

most of the linear or nonlinear coherent receivers (such as linear zero-forcing, minimum mean-square error, lattice reduction, and sphere decoding) require either channel matrix inversions or channel matrix decompositions, which are difficult to execute in an efficient and parallel manner. This can cause a bottleneck for the implementation of advanced channel equalizers or multiuser detectors at the receiver side. An exception could be the matched-filter algorithm, which is of low-complexity and parallel computing architecture. On the other hand, matched filtering is often too suboptimum for most wireless applications. One might also argue for parallel computing abilities of brute-force search, likelihood ascent search, or Tabu search. However, those algorithms trade off complexity for parallel computing, and thus they are not cost-effective solutions. In this paper, we will study the merits of deep-learning assisted solutions, with specific to their inborn parallel computing ability.

2) Conventional hand-engineered PHY algorithms face the fundamental trade-off between performance and complexity. Optimum algorithms are often too complex to implement and low-complexity algorithms are often too suboptimum. Deep-learning assisted PHY algorithms have the potential to achieve (near-)optimum performances with low computation complexities. We argue for the merits of performance-complexity trade-off when using deep learning.

3) Current PHY technologies are designed for linear communication channels and they are not optimized for future wireless systems often operating in nonlinear conditions. Nonlinear systems are often much harder for mathematical analysis, and in general, we even do not know their channel capacities. Hand-engineered approaches for PHY design and optimization are currently very challenging; and this is where deep learning can be of much assistance.

4) Sensing and communication is an emerging concept in the scope of network automation. Basically, wireless networks are able to capture environmental changes through local and remote sensors or even live video records, based on which networks can adapt their operating states for optimum uses of their local radio resources. On the PHY layer, environmental information can be translated into channel-side information through machine learning [2], and this can be useful for advanced modem functions such as adaptive modulation, coding and beamforming. In addition, machine learning can play a central role in building and reconfiguring state machines for local networks through extensive online background learning.

5) Since Shannon's ground-breaking work on communication theory reported in 1948, most telecommunications research effort has been targeting the Level A problem, i. e., how accurately can the information-bearing symbols be conveyed from one point to another? In the academic domain, this research problem has been almost saturated. In the industrial domain, it is very challenging to apply the outcome of Level A research so as to satisfy the growing demand of future

wireless networks in terms of smart connectivity, providing seemingly zero latency and perceived infinite capacity. Therefore, it is perhaps the right time to revisit or invest more research effort on the Level B problem, i. e., how precisely do the symbols of communication convey the desired meaning? This problem goes well beyond traditional source encoding practices; as for now, source encoders are expected to understand the meaning of objects instead of just the probability distribution. A simple example of the Level B problem is illustrated in Fig. 1, where the picture on the left-hand side is the original picture for transmission. Instead of compressing the picture using current codec processing methods, source encoders that have been trained to understand the meaning of the picture could send a textual description, such as "a white background picture, with a mother kangaroo carrying her baby in her pouch." The receiver then rebuilds the picture based on the meaning of the received symbols; this can be termed semantic communications, which involves heavy use of artificial intelligence/machine learning in semantic source encoding and decoding.

Certainly, we shall be able to find more merits and interesting topics when applying artificial intelligence/machine learning in wireless communications; some are already under fast development and some are just emerging. In the following sections, our discussion will be mainly focused on points 1), 2), and 3), as they are suitable for both current and future communication networks. We will also discuss fundamental bottlenecks when applying deep learning to wireless modem design.

The rest of this paper is organized as follows. Section 2 outlines the principles of deep learning assisted modem design in the wireless communication physical layer. Section 3 provides the design details of three practical physical layer applications. Section 4 provides further discussions and open research problems. Section 5 draws the conclusion.

2 Principles of Deep Learning Assisted Modem Design

By deep learning, we often mean machine learning through deep artificial neural networks (ANNs). An ANN is called deep when it has two or more hidden layers. Mathematically,

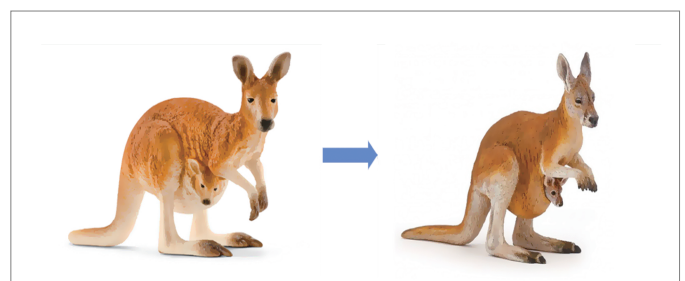

▲ Figure 1. A simple example of Level B communication problem (semantic communication).

the main function of each hidden layer is to perform classification of input vectors which might be referred to as perception in the artificial intelligence domain. If each output neuron yields a binary-type output, a hidden layer, consisting of L neurons, is able to classify at least L clusters. When a hidden layer is trained according to the nearest-neighbor rule, the machine is able to learn optimum classifications [3]. One might also employ the k -nearest neighbor rule to train the hidden layer, and in this case, the machine can form at most 2^L clusters. This is a possible way to scale up ANN when input vectors have to be partitioned into clusters that are growing exponentially. However, we will have to trade off the classification accuracy.

Prior to studying deep learning assisted wireless modem design, let us have a brief review of the PHY procedure of point-to-point communications (Fig. 2). Basically, signal waveforms are drawn from a finite-alphabet set, say A , with the size J . After going through the fading channel, received waveforms in their discrete-time equivalent form are vectors forming an infinite set. The role of receivers is to map the received vectors back onto the finite-alphabet set A . This procedure mimics the ANN-based classification procedure, as described above. Indeed, it is rather straightforward to replace the receiver box in Fig. 2 with an ANN black-box. The input vectors are formed by received waveforms combined with the channel state information, as they together form a bijection to the original waveform set A . Alternatively, the input vectors can be channel-equalized signals which also form bijection with the original waveform set A . The bijection allows the ANN black-box to be trained through supervised learning. In fact, this example is not the only way to apply deep learning for modem designs. It is also possible to replace both the transmitter and receiver with their corresponding ANN black-boxes, so as to form an autoencoder which can be trained end-to-end for joint transmitter and receiver design [4], [5]. Theoretically, a shallow-ANN (i. e. an ANN with a single hidden layer) would be sufficient to perform signal classification at the receiver side, as a receiver is normally a single-task classifier. Joint transmitter and receiver designs (autoencoders) are different, as they need at least one hidden layer at the transmitter side to construct the waveform set and another hidden layer at the receiver side to carry out corre-

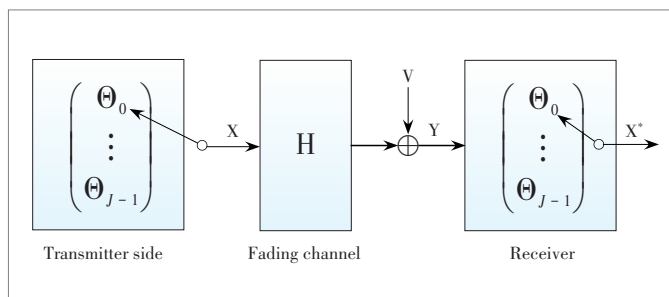

▲ Figure 2. Block diagram of the physical-layer (PHY) procedure of point-to-point communication.

sponding signal classification. Here, the implication is that deep-ANN is more meaningful when a PHY module or procedure can have a breakdown of two or more different tasks; or otherwise, a shallow-ANN would be more than enough. This issue will be further elaborated in Section 3.

In addition to the ANN architecture, ANN training algorithms or methods are crucial when improving machine learning efficiency. Analogous to ANN-assisted machine learning practices in the general artificial intelligence domain, it is always important to pay particular attention to the following three aspects:

1) Weighting vectors (including biases) in each hidden layer should be carefully initialized. They are often randomly generated according to a certain independent probability distribution within a certain range, which can vary from case to case in practical applications. Specific to modem design, we should bear in mind that those weighting vectors during training become reference vectors for the eventual signal classification. Therefore, they should be initialized in a way that facilitates the capture of the characteristics of communication signals by machines.

2) Activation functions must be carefully selected to improve the optimality or efficiency of ANN-assisted machine learning. For instance, Softmax(.) is suitable for small-scale ANNs to adopt the nearest-neighbor rule in machine learning. This enables Euclidean-distance optimality when training a hidden layer. Moreover, Softmax(.) allows machines to produce soft outputs that are often useful for soft-demodulation and decoding practices. Alternatively, we can employ Sigmoid(.) to scale up ANNs when they are expected to handle massive-region classifications. Certainly, we will have to pay for the classification optimality. For more information, a relatively comprehensive list of activation functions as well as their descriptions can be found in [6].

3) Backpropagation (BP) is essential at the ANN training stage to recursively update neuron weighting vectors, with the aim of minimizing the loss function such as the mean-square error, mean absolute error or categorical cross-entropy between the ANN output and labeled training target, depending on the applications. A commonly used BP method is called mini-batch gradient descent, which randomly picks up a certain number of training samples from the entire training data set on each training iteration. Compared to another commonly used BP algorithm called batch gradient descent, mini-batch gradient descent can significantly reduce computational complexities, particularly when the path to the desired minima is quite noisy.

3 Deep Learning Assisted Modem Designs and Their Merits

In this section, we will offer three case studies on deep-learning assisted wireless modem design and argue for their ad-

vantages in computing latency reduction, remarkable complexity-performance trade-off, as well as robustness to nonlinear physical distortions.

3.1 Case Study 1: Deep Learning Assisted Parallel Decoding of Convolutional Codes

Error-control codes often have a serial computing architecture in nature due to correlations amongst codeword bits. This fact is challenging the design of parallel-computing ready decoding algorithms. Recent advances towards ANN-assisted decoders are mainly based on recurrent neural networks [7], [8] and there is a clear show of advantages in performance-complexity trade-off. Here, we review a more recent contribution in this domain, which proposes to the employment of feed-forward neural networks for low-complexity parallel decoding of convolutional codes [9].

The basic idea is to partition a long convolutional codeword into a number of pieces, forming so-called sub-codewords. When the length of sub-codewords is sufficiently long, there exists a bijection between sub-codewords and their corresponding original information bits, subject to an initial state uncertainty. As depicted in Fig. 3a, sub-codewords are first decoded in parallel using a list maximum-likelihood decoder (List-MLD), and then initial state uncertainties are removed through the sub-codeword merging process, referred to as a two-stage decoding process that can be implemented in parallel. In this case study, the role of the ANN is to replace the List-MLD al-

gorithm at the sub-codeword decoding stage, as the latter is of very high computation complexity. Fig. 3b illustrates the ANN training procedure, where the sub-codeword decoder is modelled as a deep-ANN black-box. The input vector is the noisy version of all possible sub-codewords, and the output vector is the corresponding estimate of the original information bits. It is worthwhile highlighting that the training set of input vectors should be carefully defined so as to incorporate the effect of initial state uncertainty (as detailed in [9]), as this is crucial for the sub-codeword merging stage. Moreover, it is suggested to partition a long convolutional codeword evenly, as in this case we only need to train one ANN block-box and can reuse it for all sub-codewords, thus resulting in an efficient way to reduce the training complexity.

Fig. 4 illustrates the bit reliability of convolutional decoders in additive white Gaussian noise (AWGN), considering a half-rate non-recursive convolutional code with a codeword length of 64. The illustrated simulation results are only for $E_b/N_0=4$ dB and similar conclusions can be drawn for other E_b/N_0 values [9]. The ANN black-box was trained at $E_b/N_0=2$ dB. When comparing the parallel decoder with the conventional MLD, it can be seen from Fig. 4 that they have no difference in bit reliability; and thus, the parallel decoder is optimum. Moreover, due to the parallel computing nature, the parallel decoder has the potential to reduce computing latency, subject to the number of sub-codewords. When the sub-codeword decoder is realized through the ANN black-box described in Fig. 3b, we can

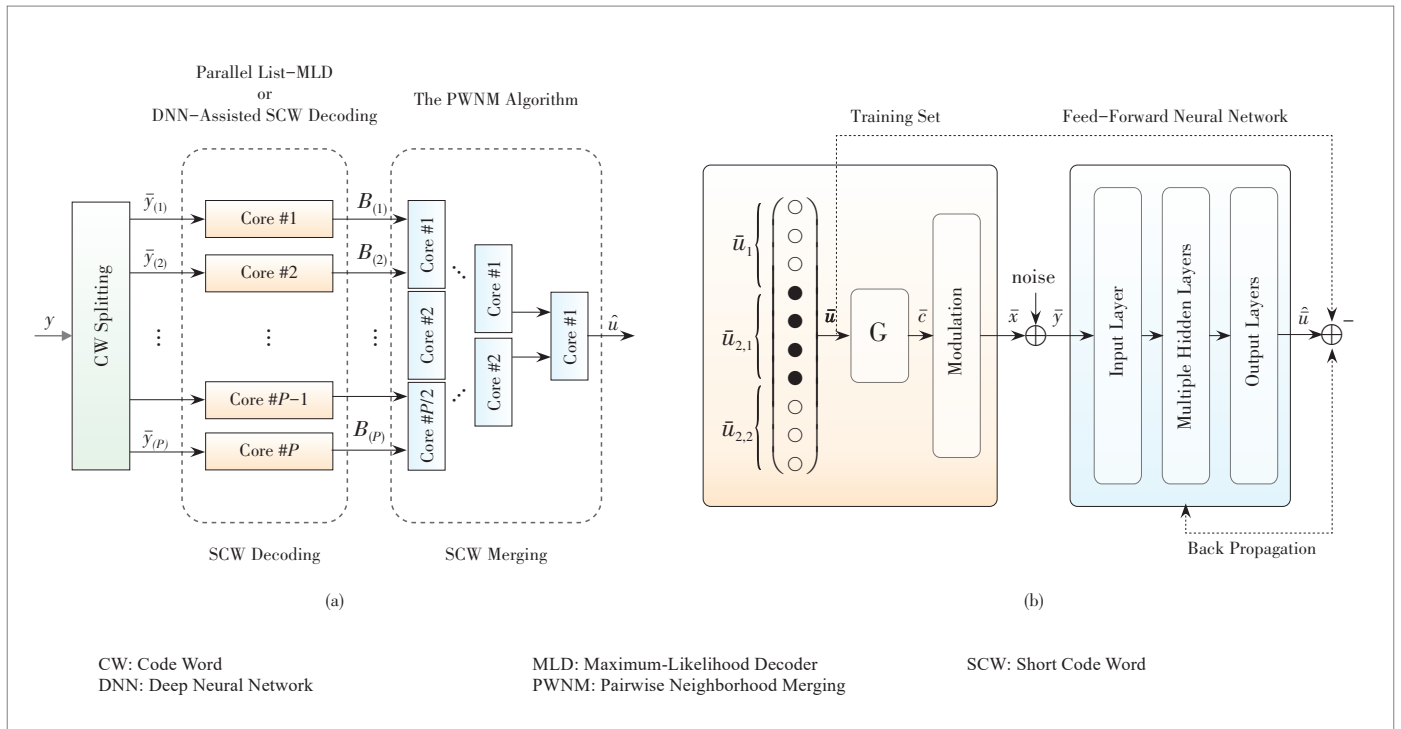

▲ Figure 3. An artificial neural network (ANN)-assisted parallel decoder: (a) two-stage parallel decoding and (b) ANN-assisted sub-codeword decoder. There are three hidden layers, with each employing Rectified Linear Unit (ReLU) activation function; the output layer is equipped with sigmoid activation function, which outputs the estimated original information bits.

see a little bit of a performance loss in bit reliability (around 0.03%); this is mainly due to using an insufficient number of epochs during the ANN training stage. Nevertheless, the computation time for sub-codeword decoding is reduced by around 95%. It is clear that ANN helps to achieve a very good complexity-performance trade-off. In addition, the ANN decoder can be executed fully in parallel and this is an additional advantage for latency reduction.

3.2 Case Study 2: Deep Learning Assisted Multiuser OFDMA Frequency Synchronization

Consider a multiuser frequency-synchronization problem in the context of orthogonal frequency-division multiple-access (OFDMA) uplink communications, where transmitters experience independently generated carrier-frequency-offsets (CFOs), due to oscillator instability or Doppler-induced ran-

dom frequency modulations. This problem involves two sub-problems. One is the multiuser-CFO estimation and the other is multiuser detection (MUD) or multiuser interference (MUI) cancellation given the CFO estimates. Multiuser-CFO estimation can be implemented by employing either pilot-assisted approaches or blind approaches that exploit statistical behaviors inherent in signal waveforms. When CFO estimates are assumed available at the transmitter side, each transmitter can carry out CFO pre-compensation, individually. However, link-level latency will be a considerable issue due to the CFO feedback delay. Alternatively, multiuser frequency synchronization can also be carried out at each individual user domain (e.g., sub-band) using the filterbank approach, which can be combined with iterative parallel interference cancellation (PIC). However, such a method is vulnerable to the CFO estimation accuracy and it could introduce extra baseband processing latency into the system.

Fig. 5 illustrates a deep-learning assisted multiuser frequency synchronization approach, named classification-and-then-MUD (CAT-MUD) in [10]. The deep-ANN has two functional layers: one is responsible for multiuser-CFO classification and the other is for the MUI cancellation. The CFO classifier is employed to tell the CFO sub-range where transmitters' CFOs fall in. This is very different from the conventional CFO estimation in the sense that the classifier only estimates the CFO range instead of CFOs. With the estimated CFO sub-range index, received signals are then fed into the MUD layer for the MUI cancellation; please find a detailed introduction of CAT-MUD in [10].

Fig. 6 illustrates the overall system performance (in block-error rate, BLER) for OFDMA systems, where 4 transmitters evenly share 32 subcarriers. Original information bits are first modulated into 16-QAM symbols and then transmitted through an 8-tap frequency-selective Rayleigh fading channel (3GPP Channel Model A). To be more robust to CFO classification er-

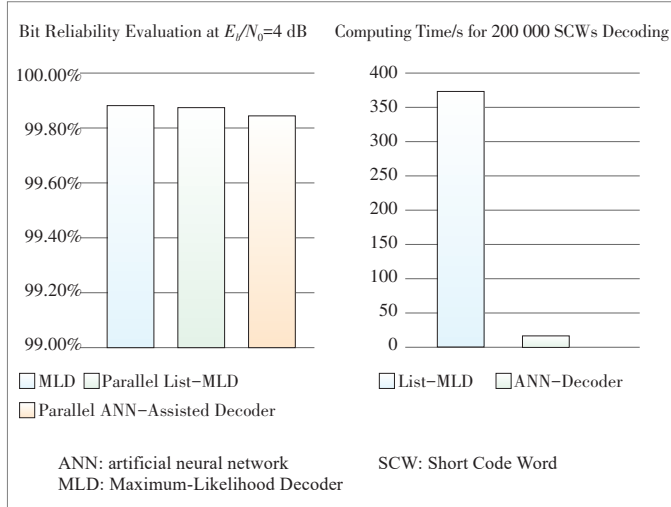

▲ Figure 4. Bit reliability and latency evaluation for decoding of half-rate non-recursive convolutional codes with a codeword length of 64.

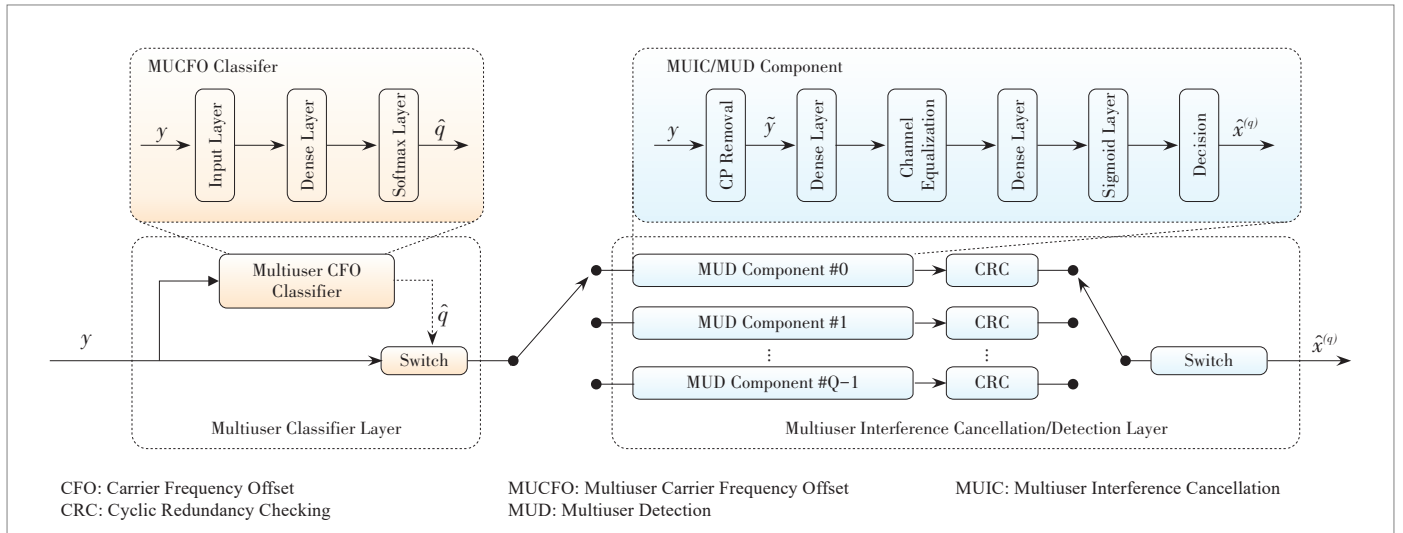

▲ Figure 5. Block diagram of the deep artificial neural network (deep-ANN) assisted classification-and-then-multiuser-detection (CAT-MUD).

rors, the switch depicted in Figure 5 can simultaneously turn on multiple adjacent MUD branches. Figure 6 shows that the 3-branch model achieves the best performance-complexity trade-off. It outperforms the conventional PIC approach by around 3 dB in E_b/N_0 and offers comparable performances with the CFO-free case at low and moderate SNRs (such as $E_b/N_0 < 15$ dB).

3.3 Case Study 3: Deep Learning Assisted Coherent MIMO Detection

Multuser multiple-input multiple-out (MU-MIMO) signal detection over noisy fading channel is mathematically an integer least-squares (ILS) problem, which aims to minimize the pairwise Euclidean distance between the transmitted signal multiplied by channel matrix and the received signal [11]. Concerning the optimal MLD solution to be computationally expensive, the usual practice is to employ linear channel equalization algorithms, such as the matched filter (MF), zero forcing (ZF) and linear minimum mean-square error (LMMSE), to trade off the optimality for lower computational complexity. However, linear algorithms are often too sub-optimum due to their use of symbol-by-symbol detection. Therefore, enormous research efforts have been paid in the last two decades to achieve the best performance-complexity trade-off through the use of non-linear algorithms (e. g., Vertical-Bell

Laboratories Layered Space-Time (V-BLAST) [12], Linear Minimum Mean-Square Error-Successive Interference Cancellation (LMMSE-SIC [13], and so on). The problem is that most of the non-linear algorithms are too complex for current DSP technology and do not lend themselves well to parallel computing. This goes against the trend of computing technology development.

Deep learning assisted solutions have demonstrated their potential for offering computational complexity close to linear receivers, without compromising the detection performance. Moreover, most of the deep learning algorithms are parallel computing ready. According to the ways of utilizing channel state information at the receiver side (CSIR), deep-learning solutions can be divided into two categories: channel equalization and learning (CE-L) mode (Fig. 7a) and direct learning (Direct-L) mode (Fig. 7b). The difference is that the CE-L mode employs ANN black-box after channel equalization, and the Direct-L mode takes both CSIR and received signal as the input vector for signal classification.

A major advantage of the CE-L mode lies in the use of channel equalization for multiuser signal orthogonalization. Hence, the input vector to the ANN black-box is effectively a noisy version of the transmitted signal vector. By such means, the CE-L mode can turn the ANN classification problem from the vector level to the symbol level. However, the performance of

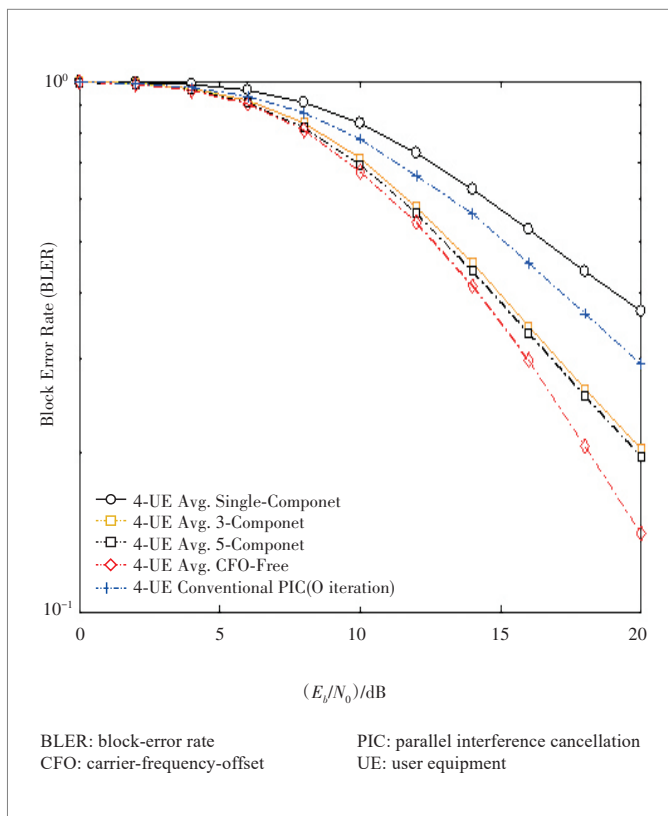

▲ Figure 6. BLER of classification-and-then-multiuser-detection (CAT-MUD) as a function of E_b/N_0 (dB) over Rayleigh fading channels.

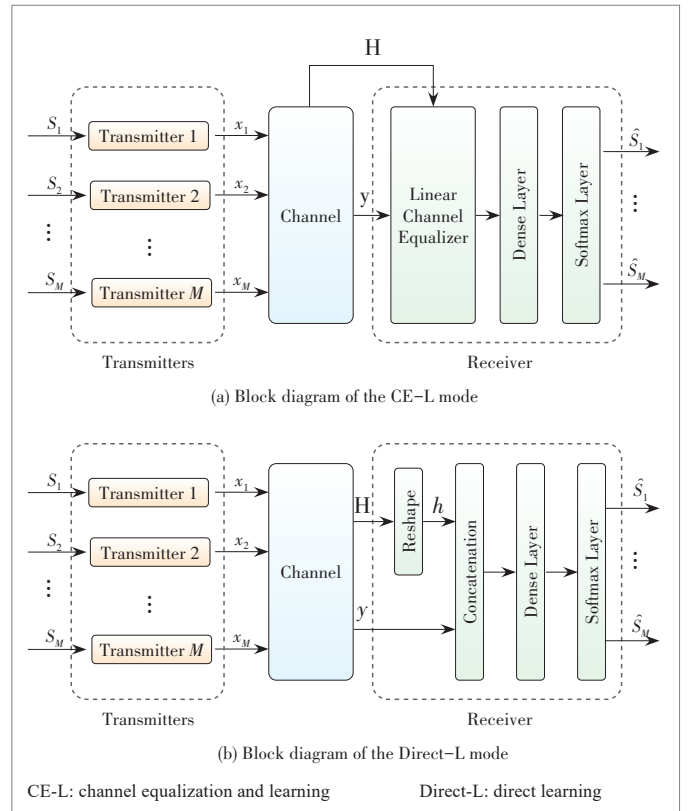

▲ Figure 7. Block diagram of deep-learning assisted multiuser multiple-input multiple-out (MU-MIMO) detection algorithms.

the CE-L mode is limited by the symbol-by-symbol MLD bound. Theoretically, the Direct-L mode is able to achieve the optimum MLD performance for the vector-level classification. In addition, the Direct-L mode does not need channel equalization. This is a remarkable advantage as channel equalizers often require channel matrix inversions which do not support parallel computing. On the other hand, the Direct-L model is not a scalable approach with the size of MIMO, due to ANN's reduced classification ability with the growth of multiuser interferences.

Fig. 8 illustrates a novel deep-ANN approach, where a multi-layer modularized ANN is combined with PIC to scale up the Direct-L mode. This approach is called DNN-PIC in [14]. Basically, the entire ANN consists of a number of cascaded PIC layers, with each layer employing a group of identical pre-trained DNN-PIC modules for signal classification and interference cancellation. Therefore, multiuser interference decreases linearly with the feed-forward procedure, and the last layer is able to provide a better classification of MU-MIMO signals.

Fig. 9 compares the average bit-error-rate (BER) performance between conventional MU-MIMO receivers and the DNN-assisted solutions. For the CE-L and Direct-L mode, the ANN was trained at $E_b/N_0=5$ dB. For the DNN-PIC approach, the ANN was trained at three different E_b/N_0 points (i. e. $E_b/N_0=0$ dB,

5 dB and 10 dB), and were optimally selected in the communication procedure in order to obtain the best achievable performance. Simulation results show that deep learning modules largely improve the detection performance of the MF-based receiver (around 8 dB at BER of 10^{-3}) due to better use of the sequence-detection gain. For both the ZF and LMMSE receiver, the sequence-detection gain vanishes since channel equalization orthogonalizes multiuser signals. Meanwhile, the Direct-L mode significantly outperforms all CE-L modes and this result confirms the accuracy of the theoretical analysis. Finally, the proposed DNN-PIC approach further improves the BER performance of the Direct-L approach by around 1.5 dB. The performance gap between the DNN-PIC and the MLD receiver is only about 0.2 dB. Again, it should be emphasized that the DNN-PIC approach is parallel computing ready.

4 Discussion and Research Challenges

Although deep learning has achieved widespread empirical success in many areas, the applications of deep learning for wireless communication physical layer design are still at the early stage of research and engineering implementation. In this section, we list several fundamental bottlenecks together with the potential future research directions.

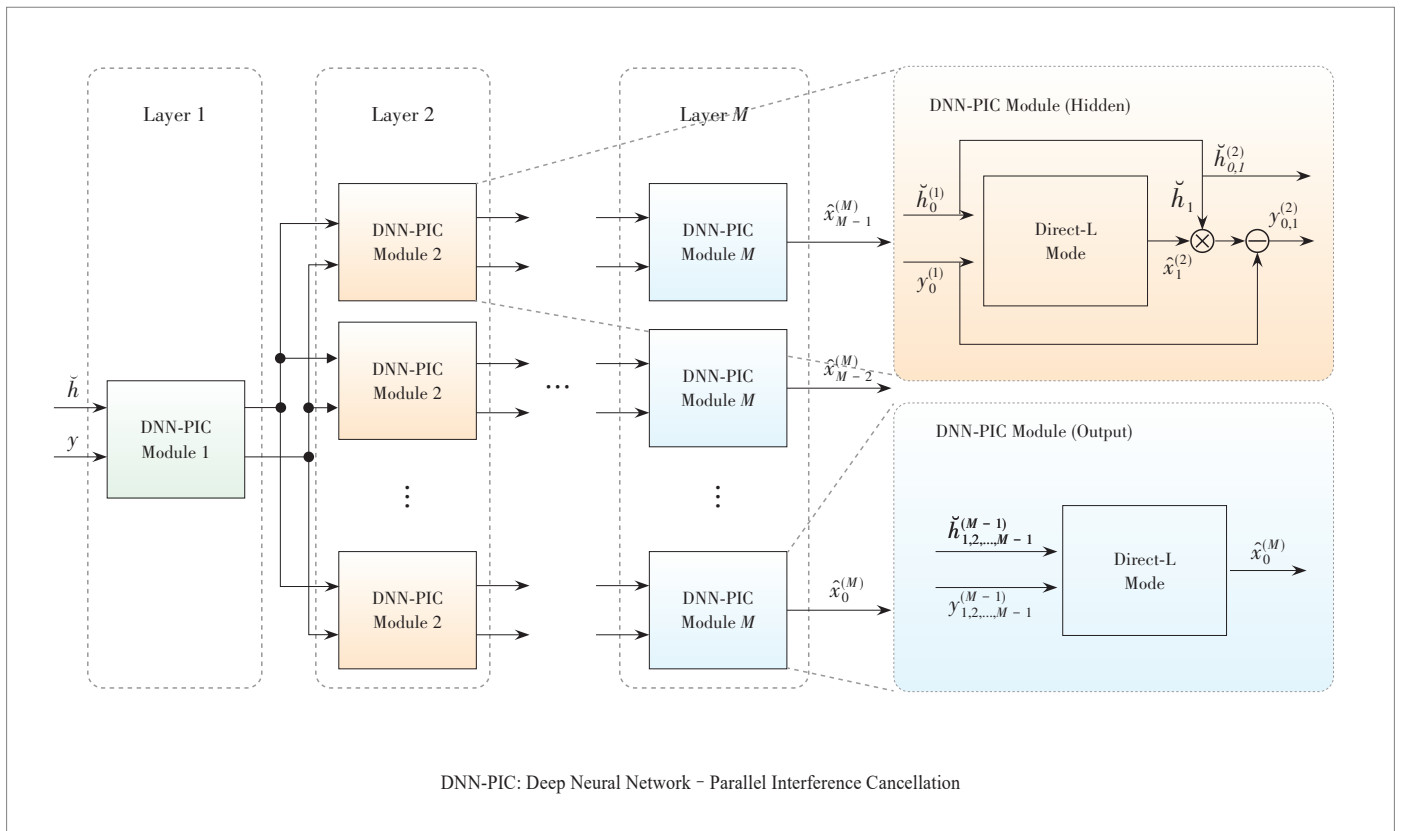

▲ Figure 8. Block diagram of the DNN-PIC approach.

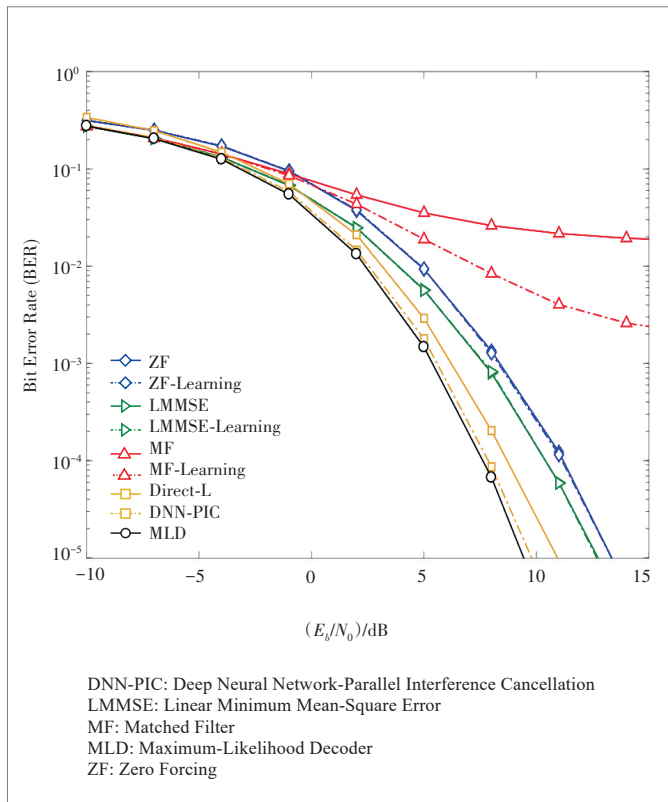

▲ Figure 9. Average BER as a function of E_b/N_0 for uncoded 4-by-8 multiuser multiple-input multiple-out (MU-SIMO) system with BPSK modulation.

1) Training set overfitting.

Overfitting is a modeling problem which occurs when a function too closely fits a limited data set [15]. In PHY, it could refer to the case that an ANN-assisted receiver trained for a specific wireless environment (or channel model) is not suitable for another environment (or channel model). It is a severe problem since a deep learning solution with limited generalization capability is less useful in real practice. However, this issue can be viewed more positively if deep learning algorithm can be used to optimize wireless receivers integrated into access points based on their local environments.

2) Scalability of DL-based solutions.

In machine learning theory, scalability refers to the effect of an increasing training data set on the computational complexity of a learning algorithm. For instance, the ANN solution in Fig. 7b has its learning capacity rapidly degraded with the growth of transmit antennas [14]. The current approach to mitigate this problem is by means of training the ANN with channel equalized signals (Fig. 7a). However, in this case, ANN-assisted receivers are not able to exploit maximally the spatial diversity-gain due to the multiuser orthogonalization enabled by channel equalizers, and the performance goes far from optimum. To tackle this issue, novel deep learning algorithms with good scalability are required (and expected) in the future.

3) Training strategies and performance evaluation.

Deep learning for wireless communication is a new research area and people lack experience in training strategies. For example, the optimal training SNR points for different PHY scenarios remain unknown [15]. In [9], it can be observed that the training of an ANN at relatively high SNRs gives an excellent generalization performance at low SNR regime in AWGN channel. However, when wireless channel becomes fading [14], the learned PHY feature at high SNR regime can no longer indicate the feature of low SNRs. A potential solution is to train ANNs at different SNR regimes separately and then merge the results together, but this solution introduces additional training complexities and requires SNR estimation. A related question is whether there is a more appropriate way to measure the training process in PHY solutions. It is well known that ANN training aims to minimize a given loss function, and we consider that an ANN is well trained if the loss is converged to an ideal state. On the other hand, PHY performance is normally measured by BER or SER. In most of the ANN-assisted PHY solutions, we make a hard decision on ANN outputs to obtain the bit-level (or symbol-level) estimates. However, the loss function might not be able to accurately indicate the training progress when complicated PHY scenarios are considered (e. g., high-order modulation and fast fading channel). In [14], the authors introduce a method which measures the training progress by computing the average BER/SER over the last few training epochs, and the estimated BER performance is shown to be very close to the validation performance. In general, the training strategies, especially for PHY applications, are worthy of investigation in future research.

4) Hardware implementation.

Currently, most of the ANN-assisted PHY solutions are still in their software simulation stages, but hardware implementation normally requires more practical considerations [16] - [18]. Apart from the channel model and data set that we have discussed in the previous sections, power consumption also needs to be considered since the ANN training process often involves very high computation cost. The aim of reducing ANN learning expenses has recently motivated a new research area on the non von Neumann computing architecture.

5 Conclusions

This paper presents several promising ANN-assisted PHY applications. The idea lies in the use of ANNs to replace parts of the conventional signal processing blocks in the communication chain. It is shown that ANN-assisted approaches achieve competitive performance in terms of both reliability and latency in various applications. More importantly, deep learning offers us a fundamentally new way to design and optimize the conventional communication systems. A wide range of open challenges need to be solved and theoretical analysis is also expected in future research.

References

- [1] FG-NET-2030. Network 2030: Blueprint of Technology A, Applications and Market Drivers Towards the Year 2030 and Beyond [EB/OL]. (2019-05-20). https://www.itu.int/en/ITU-T/focusgroups/net2030/Documents/White_paper.pdf
- [2] O'SHEA T J, ERPEK T, CLANCY T. Deep Learning Based MIMO Communications [EB/OL]. (2017-07-25). <https://arxiv.org/abs/1707.07980>
- [3] NAOUM R S, AL-SULTANI Z N. Learning Vector Quantization (LVQ) and K-nearest Neighbor for Intrusion Classification [J]. *World of Computer Science and Information Technology Journal*, 2012, 2(3):105–109
- [4] O'SHEA T J, HOYDIS J. An Introduction to Deep Learning for the Physical Layer [J]. *IEEE Transactions on Cognitive Communications and Networking*, 2017, 3(4): 563–575. DOI: 10.1109/TCCN.2017.2758370
- [5] XUE S Y, MA Y, YI N, et al. Unsupervised Deep Learning for MU-SIMO Joint Transmitter and Noncoherent Receiver Design [J]. *IEEE Wireless Communication Letter*, 2019, 8(1): 177–180. DOI: 10.1109/LWC.2018.2865563
- [6] BIRCANOGLU C, ARICA N. A Comparison of Activation Functions in Artificial Neural Networks [C]/Signal Processing and Communications Applications Conference (SIU), Izmir, Turkey, 2018: 1–4. DOI: 10.1109/SIU.2018.8404724
- [7] HAMALAINEN A, HENRIKSSON J. Convolutional Decoding Using Recurrent Neural Networks [C]/International Joint Conference on Neural Networks. Washington, DC, USA, 1999: 3323–3327. DOI: 10.1109/IJCNN.1999.836193
- [8] PAYANI A, FEKRI F. Decoding LDPC Codes on Binary Erasure Channels using Deep Recurrent Neural-Logic Layers [C]/IEEE International Symposium on Turbo Codes & Iterative Information Processing (ISTC), Hongkong, China, 2018: 1–5. DOI: 10.1109/ISTC.2018.8625326
- [9] WANG J, MA Y, XUE S Y, et al. Parallel Decoding for Non-Recursive Convolutional Codes and its Enhancement Through Artificial Neural Networks [C]/IEEE International Workshop on Signal Processing Advances in Wireless Communications. Cannes, France, 2019: 1–1
- [10] LI A, MA Y, XUE S Y, et al. Unsupervised Deep Learning for Blind Multiuser Frequency Synchronization in OFDMA Uplink [C]/IEEE International Conference on Communications. Shanghai, China, 2019: 1–1. DOI: 10.1109/ICC.2019.8761937
- [11] DE LUNA DUCOING J C, MA Y, YI N, et al. A Real-Complex Hybrid Modulation Approach for Scaling up Multiuser MIMO Detection [J]. *IEEE Transactions on Communications*, 2018, 66(9): 3916–3929. DOI: 10.1109/TCOMM.2018.2833101
- [12] WOLNIANSKY P W, FOSCHINI G J, GOLDEN G D, et al. V-BLAST: An Architecture for Realizing Very High Data Rates over The Rich-scattering Wireless Channel [C]/URSI International Symposium on Signals, Systems, and Electronics. Conference Proceedings. Pisa, Italy, 1998: 295–300. DOI: 10.1109/ISSSE.1998.738086
- [13] LIU T, LIU Y Y. Modified Fast Recursive Algorithm for Efficient MMSE-SIC Detection of the V-BLAST System [J]. *IEEE Transactions on Wireless Communications*, 2008, 7(10): 3713–3717. DOI: 10.1109/T-WC.2008.070487
- [14] XUE S Y, MA Y, LI A, et al. On Unsupervised Deep Learning Solutions for Coherent MU-SIMO Detection in Fading Channels [C]/IEEE International Conference on Communications. Shanghai, China, 2019: 1–6. DOI: 10.1109/ICC.2019.8761999
- [15] KENTON W. Overfitting [EB/OL]. [2019-07-02]. <https://www.investopedia.com/terms/o/overfitting.asp>
- [16] GEORGE D, HUERTA E A. Deep Neural Networks to Enable Real-time Multimessenger Astrophysics [J]. *Physical Review D*, 2018, 97(4): 044039. DOI: 10.1103/PhysRevD.97.044039
- [17] DORNER S, CAMMERER S, HOYDIS J, et al. Deep Learning Based Communication Over the Air [J]. *IEEE Journal of Selected Topics in Signal Processing*, 2018, 12(1): 132–143. DOI: 10.1109/JSTSP.2017.2784180
- [18] SAHOO D, PHAM Q, LU J, et al. Online Deep Learning: Learning Deep Neural Networks on the Fly [C]/International Joint Conferences on Artificial Intelligence Organization. Stockholm, Sweden, 2018: 2660–2666. DOI: 10.24963/IJCAI.2018/369

Biographies

XUE Songyan received the B. E. degree from University of Electronic Science and Technology of China and M. S. degree from University of Surrey, the United Kingdom. He is currently pursuing the Ph. D. degree at the Institute of Communication Systems (ICS), University of Surrey. His research interests center around deep learning applications in wireless communication physical layer.

LI Ang received the B. E. degree from Northwestern Polytechnical University, China, and M. S. degree from University of Surrey. He is currently pursuing the Ph. D. degree at the Institute of Communication Systems (ICS), University of Surrey. His research interests focus on the multi-carrier waveform design for future physical layer, machine learning and non-linear transceiver optimization.

WANG Jinfei received the B. S. degree from University of Science and Technology of China, and M. S. degree from University of Surrey. He is currently pursuing the Ph. D. degree at the Institute of Communication Systems (ICS), University of Surrey. His research interests include mobile edge computing and URLLC.

YI Na is the Founder and Director of DEEPGO Ltd. She is also a Senior Research Fellow in Institute for Communication Systems (ICS), University of Surrey. She has had 15-year experience in coordination of international research projects funded by European Commission or EPSRC. She has established rich cooperation across EU, China and other parts of Asia. Her current research interests focus on machine learning for wireless networks, large-scale 5G pilot platform, and C2X communications.

MA Yi (y. ma@surrey.ac.uk) is the Head of AI Wireless Group within the Institute of Communication Systems (ICS), University of Surrey, the United Kingdom. He has authored and co-authored more than 150 IEEE journal and conference papers as well as 5 patents in the field of multiuser information theory, signal processing and machine learning for wireless communications.

Rahim TAFAZOLLI is the Director of Institute for Communications (ICS) and the Director of 5G Innovation Centre (5GIC), University of Surrey. He is the Regius Professor of Electrical Engineering in the United Kingdom. He has authored and co-authored more than 600 peer-reviewed journal and conference papers, and been the co-inventor of more than 20 patents in the field of mobile and satellite communications.

Terence DODGSON is qualified to Ph. D. level in image processing/electrical and electronic engineering/telecommunications and has a substantial technical background plus wide domain knowledge in the area of digital communications systems, research and algorithm development, implementation, system design and validation (in modern mobile communications systems such as GSM, UMTS, HSDPA, LTE, satellite communications systems and image processing systems), including artificial intelligence. He currently works for Airbus in the Modems Advanced Development Group.